



**Everlux<sup>®</sup>**

Photoluminescent maritime safety signs

# Introduction

## Technical properties of photoluminescent safety signs

Quality, Standards & Certification:

Ⓢ Everlux® photoluminescent products are manufactured to the highest technical standards using state of the art equipment; thus ensuring we offer the best available photoluminescent quality for safety signs.

Ⓢ Everlux® photoluminescent safety signs comply with IMO Resolutions, Solas Convention and ISO Standards.

Ⓢ Everlux® products have Type Approval by Lloyd's Register and are MED certified by DNV.

Technical Properties:

Luminance properties			
Applicable Standards and Resolutions/ product	Luminescent intensity (mcd/m <sup>2</sup> ) (After removing the exciting light)		Period of light decay  Luminance Intensity greater than a 0.3 mcd/ m <sup>2</sup>
	10 minutes	60 minutes	
DIN 67510-4 (R) (a)	23 mcd/m <sup>2</sup>	3 mcd/m <sup>2</sup>	...
IMO Res. A.752(18)	15 mcd/m <sup>2</sup>	2 mcd/m <sup>2</sup>	...
ISO 15370	15 mcd/m <sup>2</sup>	2 mcd/m <sup>2</sup>	...
Ⓢ Everlux® (b)	100 mcd/m <sup>2</sup>	10 mcd/m <sup>2</sup>	1200 minutes
Ⓢ Everlux® (c)	40 mcd/m <sup>2</sup>	8 mcd/m <sup>2</sup>	1800 minutes

a) class A

b) According to DIN 67510 measurement protocol;

c) According to ISO 15370 measurement protocol.

**Photoluminescent signs:** Photoluminescent rigid plastic 1.2 ± 0.1mm thickness and self-adhesive photoluminescent vinyl.

**Printing:** Serigraphy, high quality gloss paint with UV resistance and an indoor durability in excess of 5 years.

**Fire resistance:** Flame retardant according to IEC 60092-101: 2002 and IMO FTPC Part 5 (IMO Res. A.653(16)).

**Surface:** Antistatic and easy to clean.

**Chemical characteristics:** Non-radioactive, non-phosphorous, lead-free and non-poisonous.

## Safety signage is a language comprised of pictorial graphics, shapes and colors.



Color should be for everyone!

... and because colors are determinant in safety signs, Ⓢ Everlux® has associated with ColorAdd - the color identification system for colorblind people.

ColorAdd is a project which was developed with the goal of allowing colorblind people to correctly identify each color and therefore to contribute for their social integration whilst making communication more effective, responsible and inclusive. ColorAdd is an extremely intuitive symbolic language that uses the primary colors and their combination to create the entire colors/codes palette.

By including the ColorAdd system, the Ⓢ Everlux® catalogue allows colorblind people to fully comprehend all the components of safety signs.

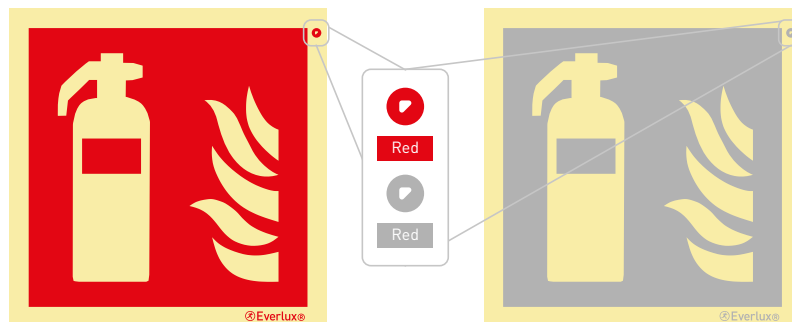

COLORS | SYMBOLS



WHITE | BLACK | GREY



GOLD | SILVER



LIGHT TONES



DARK TONES



# Index

	How to order.....	03
	Market assurance and certification.....	04
	Mounting options.....	05
	Viewing distances.....	06-08
	Life-saving appliances.....	09-12
	Escape route signs.....	13-16
	IMO fire control signs.....	17-23
	Fire fighting equipment signs.....	24-28
	ⓈEverlux® Low Location Lighting system.....	29-37
	Panoramic signs.....	38
	Marking strips.....	39
	Warning signs.....	40-42
	Mandatory signs.....	43-47
	Prohibition signs.....	48-51
	Multipurpose combination signs.....	52-53
	Information signs.....	54
	ISPS Code signs.....	55-56
	Safety signs for super yachts.....	57-58
	Offshore wind - safety signs.....	59-61
	Water safety signs.....	62-63
	Temporary tie tags.....	64
	Anti-splashing tape.....	65
	Pipe content identification.....	66-68
	IMDG Code.....	69-70
	Safety awareness and training procedures.....	71-91
	General safety awareness notices.....	92
	Safety plans.....	93
	Fire control and safety plans.....	94
	Bespoke signage solutions.....	95
	ⓈEverlux® frames.....	96
	ⓈEverlux® adhesive.....	96
	IMPA and ISSA cross reference guide.....	97-102
	Standards and regulations.....	103

## How to order

All ⓈEverlux® and ⓈEverlux®-LLL signs have a unique 5 digit code.

To order you need to indicate the following:

- 1.The product code;
- 2.The size (mm);
- 3.The type of sign (see page 5). If not indicated we will supply Type 1;
- 4.The material of the sign. Most of the ⓈEverlux® signs are available in photoluminescent rigid plastic (F) and photoluminescent self-adhesive vinyl (Z). There are several product ranges with different base materials. The complete list of sign base materials is: F - photoluminescent rigid plastic; Z - self-adhesive vinyl; O - white rigid plastic; V - white self-adhesive vinyl; VT - transparent self-adhesive vinyl PC - non-slip self-adhesive photoluminescent polycarbonate; T - aluminium composite; TA - transparent acrylic; FA - frosted acrylic; and SS - stainless steel.

(\*)Example:

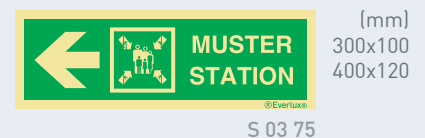

(\*) The sign on this example is available in the following sizes 300x100 and 400x120; in Type 1, 2 or 3; and in photoluminescent rigid plastic and self-adhesive photoluminescent vinyl.

To order the above sign in 400x120, Type 1 and in photoluminescent rigid plastic you order: S 03 75 – 400x120 – Type 1 - F.

It is also possible to order by IMPA or ISSA codes. Please refer to the cross reference guide on pages 97 – 102 to find the equivalent

ⓈEverlux® item code.

# Introduction

## Sign performance and technical properties

### Technical guarantees for the market

The photoluminescent properties and performance values are printed on all  Everlux® signs as per ISO and DIN Standards requirements. This provides consumers with the correct information and a guarantee of high quality. Please see the following example:

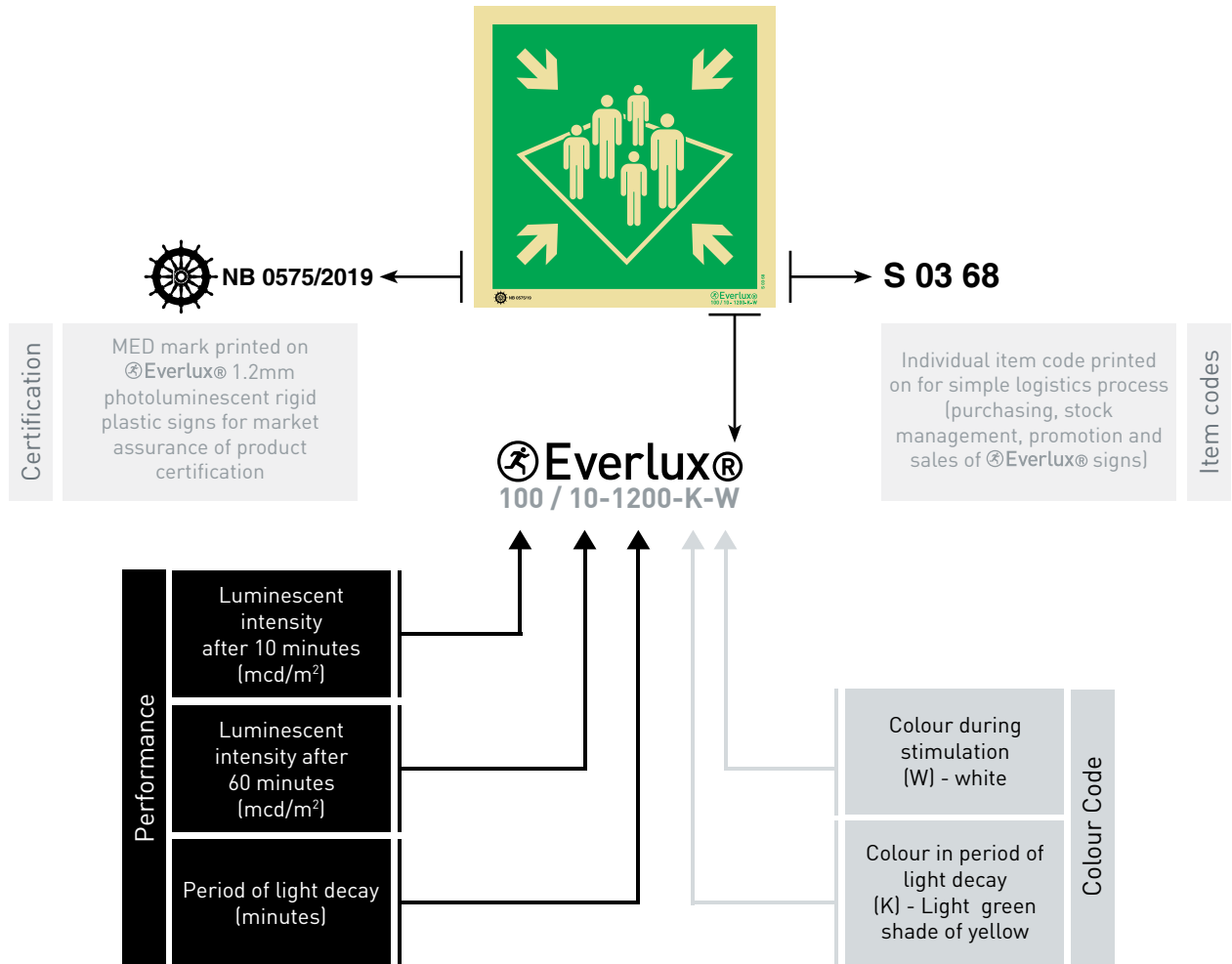

This brings the signs into alignment with other safety equipment where technical information is provided on the apparatus, e.g. extinguishers.

On all  Everlux® photoluminescent safety signs the technical properties are printed and illustrate their performance as per ISO and DIN Standards requirements. This helps specifiers and consumers to make informed decisions about the signs to be used.

The quality of  Everlux® safety signs is ensured by maintaining a continuous quality control system. All  Everlux® photoluminescent products have the Lloyd's Register Type Approval Certificate



and are certified by DNV according to MED.



The method of measuring the luminance performance according to ISO and DIN Standards is carried out in the laboratory, where all measuring equipment is calibrated by an accredited and independent official entity.

## Different types of application - various alternatives for mounting signs

For an adequate use of signs they must be mounted according to the appropriate viewing angle.

### Type 1 (single-sided)

Parallel wall mounted sign.

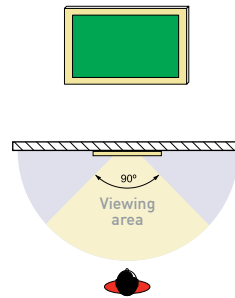

### Type 2 (double-sided)

The signs are mounted perpendicularly to the wall by means of a flexible bracket. The bracket consists of a strip that enables the installation of double-sided signs in any location and was developed with the aim of allowing the sign to swing through 180° (+90° and -90°) without breaking.

**Note:** The bracket is always mounted to the left hand side of the sign, i.e.: Picture 1 - code S 04 21 Type 2; and in Picture 2 - code S 04 26 Type 2.

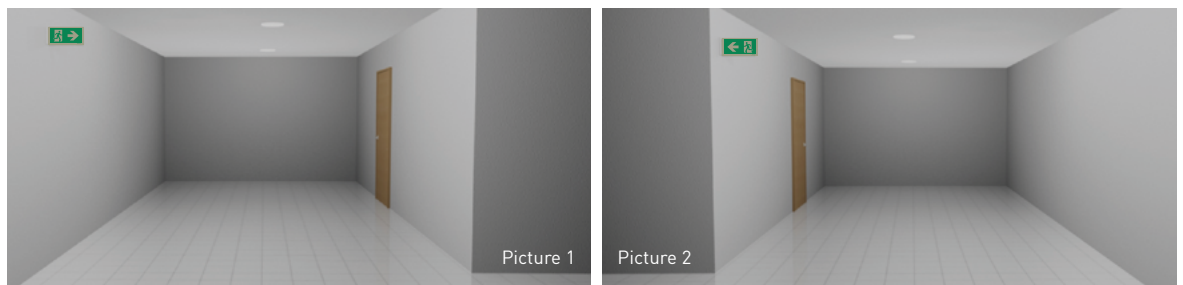
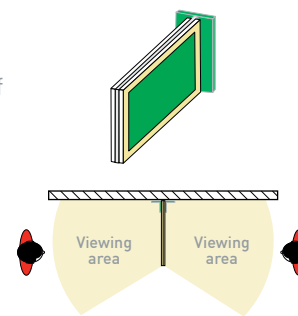

### Type 3 (double-sided)

A Type 3 suspended double-sided sign is to be hung from the ceiling. The sign is supplied with holes drilled in the top corners which allow the appropriate fixings to be used (fixings not supplied).

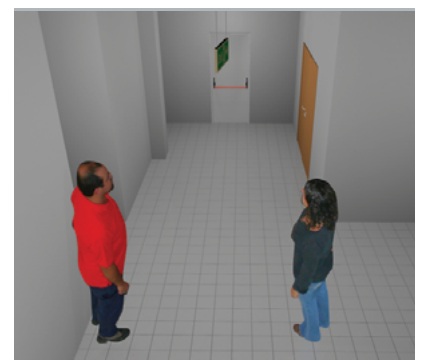
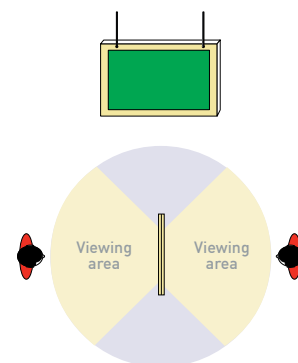

### Type P (panoramic signs)

The sign with the greatest visibility. These signs are printed on both exterior surfaces and guarantee a viewing angle of 180°.

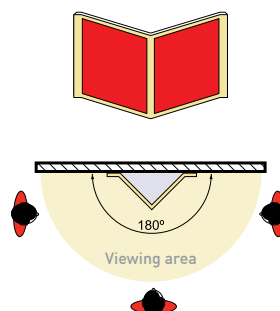

# Introduction

## Sizes and viewing distances

The size of the sign is defined by the maximum viewing distance from which the sign is understandable. According to ISO 3864-1: 2011, the viewing distance at which a sign of a particular size is conspicuous and comprehensible depends on the illumination of the sign.

$$l = z_0 \times h$$

Where:  $l$  - is the observation distance (m);  
 $z_0$  - is the distance factor;  
 $h$  - is the height of the sign (mm).

## Life-saving and emergency equipment, escape route and fire fighting equipment signs

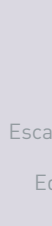
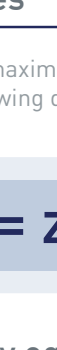
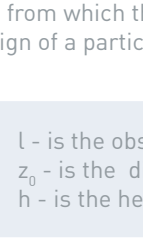
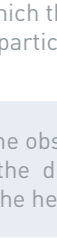
Geometric Shape	Meaning	 Everlux <sup>®</sup> sign sizes (mm)	h height of the sign (mm)	l observation distance (m)
	(z <sub>0</sub> =60)	100x100	80	5
		150x150	131	8
		200x200	180	11
		300x300	278	17
		400x400	376	23
  	Escape Route and Fire Fighting Equipment Signs (z <sub>0</sub> =60)	150x50	36	2
		150x75	55	3
		200x50	36	2
		200x70	55	3
		200x100	80	5
		300x70	57	3
		300x100	80	5
		300x150	129	8
		400x100	78	5
		400x120	98	6
		400x150	129	8
		400x200	180	11
		450x150	129	8
		600x150	129	8
		600x200	180	11
		600x300	276	17
		150x200 (*)	129	8
200x300 (*)	180	11		
300x400 (*)	276	17		

(\*) Signs with complementary text for which only the height of the pictogram is relevant for the calculation of their observation distance



## Life-saving and emergency equipment, escape route and fire fighting equipment signs

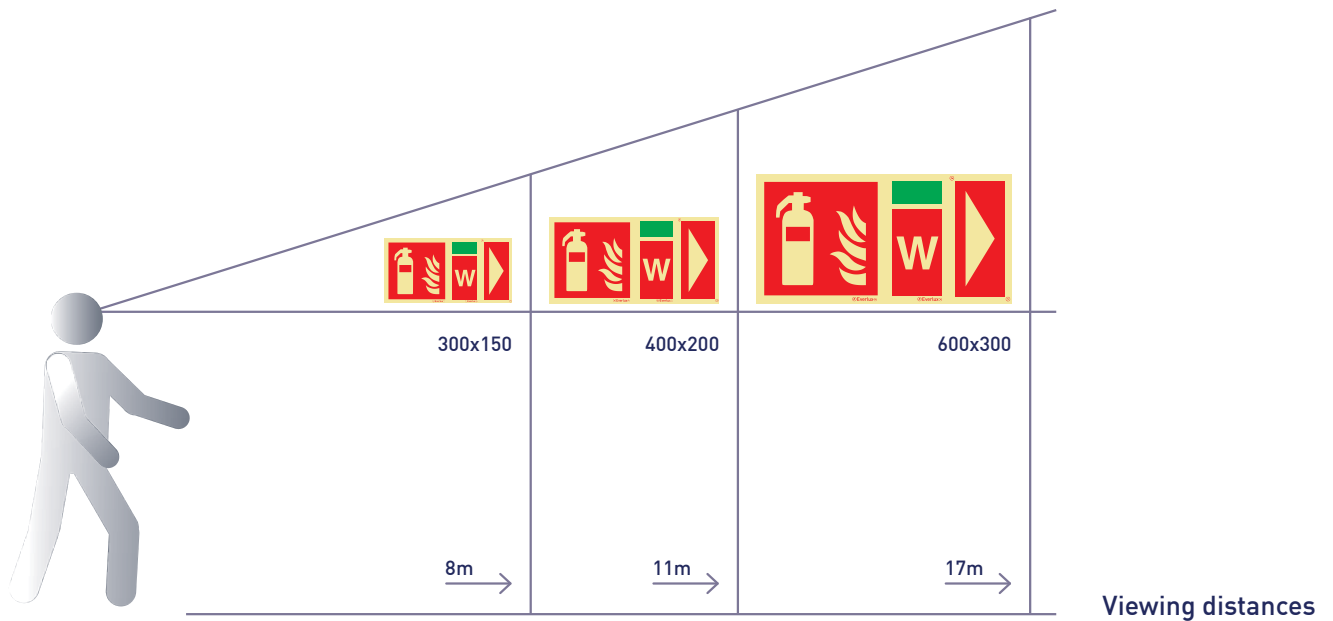

## Exception signs

Geometric Shape	Meaning	Everlux® sign sizes (mm)	h height of the sign (mm)	l observation distance (m)
	$z_0=95$ for S 04 61 and S 04 62 signs as per ISO 7010: 2011	150x150	129	12
		200x200	180	17
		300x300	278	26
		400x400	376	36

Note: The distance factor ( $z_0$ ) is assumed as a general value of 60 as defined by ISO 3864-1:2011. For ISO 7010 - S 04 61 and S 04 62 emergency exit signs the recommended value of  $z_0$  is 95 considering an illuminance range between 5 and 100 lux. Over the illuminance range up to about 100 lux,  $z_0$  increases according to ISO 3864-1:2011.

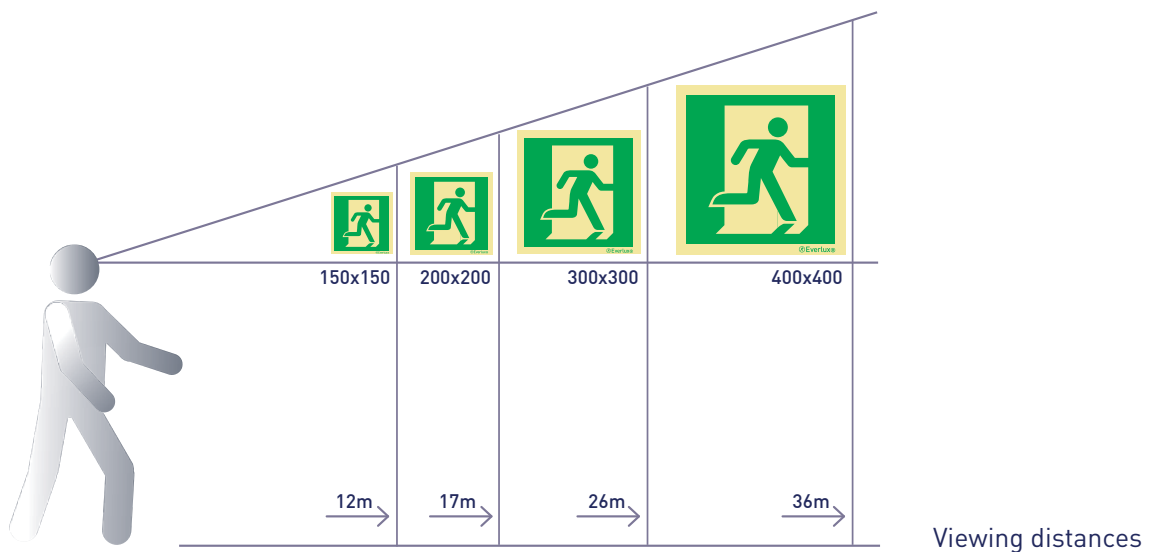

# Introduction

## Mandatory and prohibition action signs

Geometric Shape	Meaning	Everlux <sup>®</sup> sign sizes (mm)	h height of the sign (mm)	l observation distance (m)
	Prohibition and Mandatory Action Signs (z <sub>0</sub> =60)	100x100	80	5
		150x150	131	8
		200x200	180	11
		300x100	80	5
		300x300	278	17
		400x150	131	8
400x400	376	23		

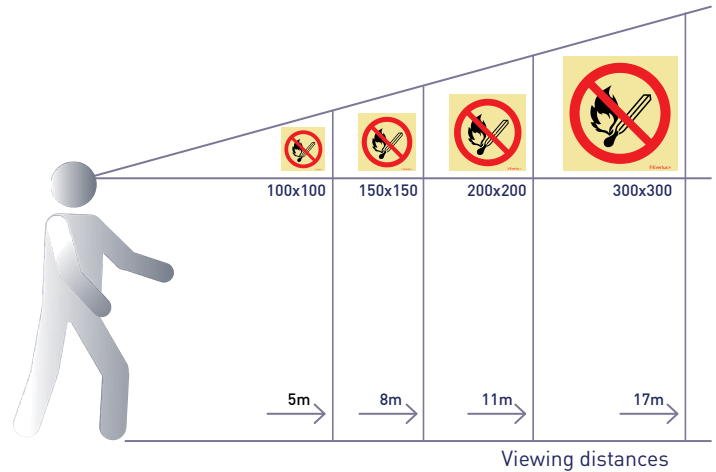

## Hazard signs

Geometric Shape	Meaning	Everlux <sup>®</sup> sign sizes (mm)	h height of the sign (mm)	l observation distance (m)
	Hazard Signs (z <sub>0</sub> =60)	base 100	56	3
		base 150	94	6
		base 200	130	8
		base 300	193	12
		base 400	264	16
		300x100	80	5
		400x150	113	7

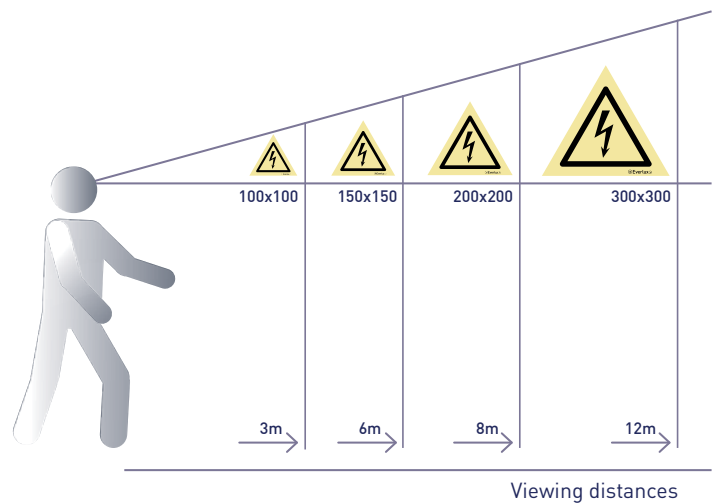

## IMO Resolution A.1116(30), adopted on 5 December 2017 – Escape Route Signs and Equipment Location Markings.

In sequence to the 2016 IMO MSC.1/Circ.1553 Shipboard escape route signs and emergency equipment location markings which invited Contracting Governments to start implementing safety signs as per ISO 24409-2:2014 on a voluntary basis, IMO Resolution A.1116(30) adopts these escape route signs and equipment location markings.

The adoption of ISO's symbols by IMO is a step forward to the needed standardization of the international symbols to indicate the location of emergency equipment to people who travel and work on-board ships and other marine installations.

IMO Resolution A.1116(30), adopted on 5 December 2017 – Escape Route Signs and Equipment Location Markings is effective for ships constructed on or after 1 January 2019 and for ships which undergo repairs, alterations, modifications and outfitting on or after that date.

The examples below illustrate some of the changes on safety signs that the adoption of IMO Resolution A.1116(30) entail:

Everlux<sup>®</sup> have been working on the inclusion of these signs as standard catalogue signs since the publication of ISO 24409-2:2014 Ships and marine technology – Design, location and use of shipboard safety signs, safety-related signs, notices and safety markings – Part 2: Catalogue.

IMO SYMBOL PRIOR TO IMO RES. A.1116(30) ADOPTION	IMO SYMBOL POST TO IMO RES. A.1116(30) ADOPTION

## Life-saving appliance IMO signs - according to SOLAS Convention (Chap. III Reg. 9.2.3.) and ISO 24409

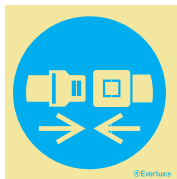

S 00 01

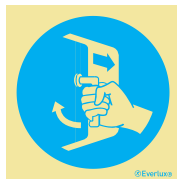

S 00 02

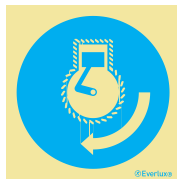

S 00 03

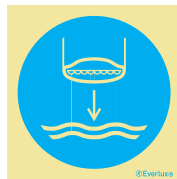

S 00 04

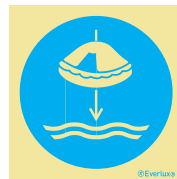

S 00 05



(mm)  
150x150  
200x200  
300x300

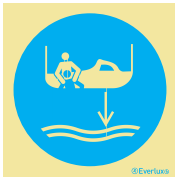

S 00 06

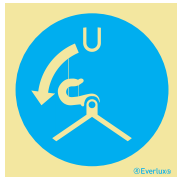

S 00 07

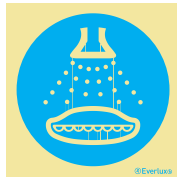

S 00 08

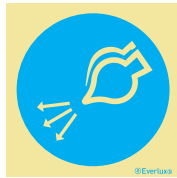

S 00 09

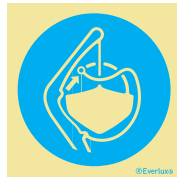

S 00 10

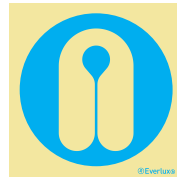

S 00 11



FASTEN SEAT BELTS

S 01 01

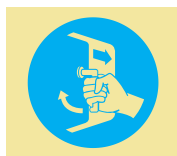

SECURE HATCHES

S 01 02

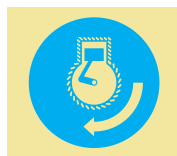

START ENGINE

S 01 03

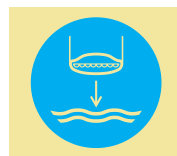

LOWER LIFEBOAT

S 01 04



(mm)  
150x150  
200x200  
300x300



LOWER LIFERAFT

S 01 05



LOWER RESCUE BOAT

S 01 06



RELEASE FALLS

S 01 07



START WATER SPRAY

S 01 08

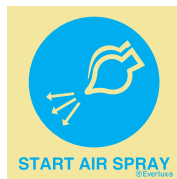

START AIR SPRAY

S 01 09



RELEASE GRIPES

S 01 10

Signs with symbols and supplementary text

# Life-saving appliances

Life-saving appliance signs - according to IMO Resolution A.760 (18), ISO 17631 and ISO 24409











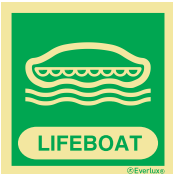





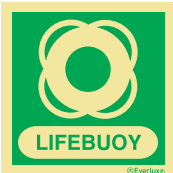



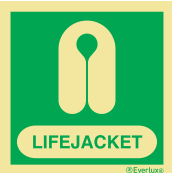

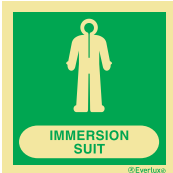



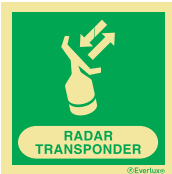





(mm)  
150x150  
200x200  
300x300

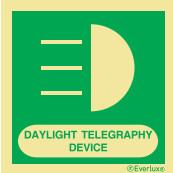

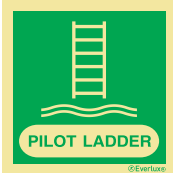





 S 02 01	 S 02 02	 S 02 03	 S 02 04		
 S 02 05	 S 02 06	 S 02 07	 S 02 08	 S 02 09	 S 02 10
 S 02 11	 S 02 12	 S 02 13	 S 02 14	 S 02 15	 S 02 16
 S 02 17	 S 02 18	 S 02 19	 S 02 20	 S 02 21	 S 02 22
 S 02 23	 S 02 24	 S 02 25	 S 02 26	 S 02 27	 S 02 28
 S 02 29	 S 02 30	 S 02 31	 S 02 32	 S 02 33	 S 14 67

## Life-saving appliance signs - according to IMO Resolution A.760 (18), ISO 17631 and ISO 24409

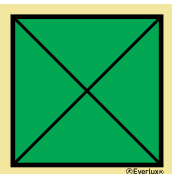
					 (mm) 150x150 200x200 300x300
S 02 51	S 02 52	S 02 53	S 02 54	S 02 55	
					
S 02 56	S 02 57	S 02 58	S 02 59	S 02 60	
					
S 02 62	S 02 63	S 02 64	S 02 65	S 02 66	
					
S 02 68	S 02 69	S 02 70	S 02 71	S 02 72	
					
S 02 74	S 02 75	S 02 76	S 02 77	S 02 78	
					
S 02 80	S 02 81	S 02 82	S 02 83	S 02 84	
					
S 02 79					
					
S 02 85					

## Non-standard Life-saving appliance IMO signs

	 (mm) 150x150 200x200 300x300			
S 14 52				
				
S 14 62	S 14 64	S 14 65	S 14 66	S 14 68

# Life-saving appliances

## Emergency equipment signs

Emergency equipment must be installed on board and their location should be clearly signed for quick identification in case of need. For example, the automated external defibrillators (AED) are being increasingly used as means of assistance to victims of cardiac arrest. Several countries already provide that AED be used on board. The MCA - Maritime and Coastguard Agency - recommends that UK-flagged ships carry AED (MGN 297 (M)); whilst in Germany, the use of AED in some German-flagged ships is mandatory according to Ordinance for the Medical Care on Seagoing Vessels, issued by the BG for Transport and Traffic, and to Guideline No. 3, issued by the Sanitation Ship Committee of German Federal States.

Since the chance of survival for cardiac arrest victims significantly increases with a prompt response, the quick identification of AED equipment is vital. The identification of these equipments must be made using photoluminescent signs.

(mm)  
150x150  
200x200  
300x300  
400x400

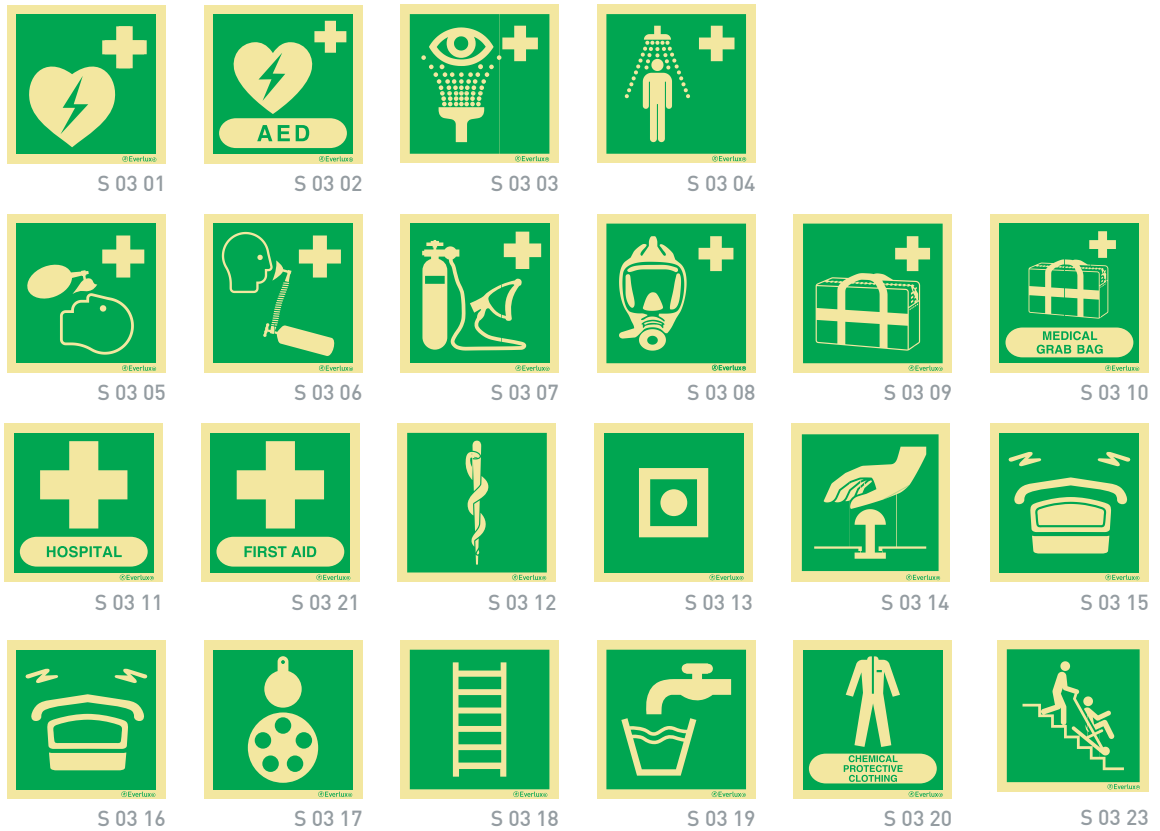





(mm)  
300x100  
400x150



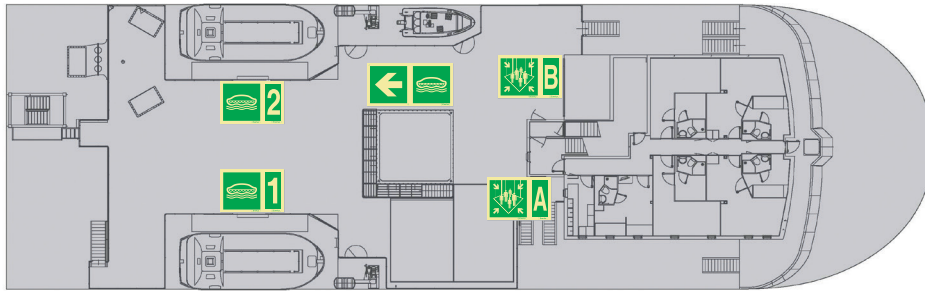

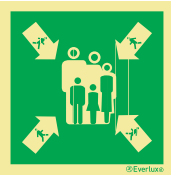
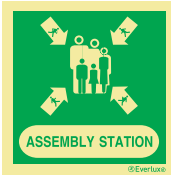

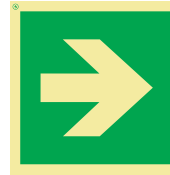
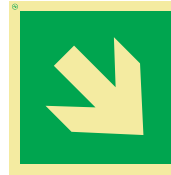
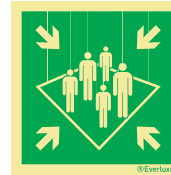













## Muster Station and Embarkation Station signs











The objective of the escape route signing system is to ensure that a sign or a series of signs is provided and placed so that a person is directed along the escape route from any space within a ship or a marine installation towards an assembly station or embarkation station. The signing system should be designed based on the means of escape plan, assembly station plan, and lifesaving plan. It should provide simple information that will make it easy to identify the means of escape provisions, allow people to escape with minimum assistance and avoid possible points of confusion.



							(mm) 150x150 200x200 300x300 400x400
S 03 61	S 03 62	S 03 63	S 03 64	S 03 65	S 03 68		

					(mm) 300x100 400x120
		S 03 71	S 03 72		
					
S 03 73	S 03 74	S 03 75	S 03 76		
					
S 03 77	S 03 78	S 03 79	S 03 80		
					
S 03 81	S 03 82	S 03 83	S 03 84		
					
S 03 85	S 03 86	S 03 87	S 03 88		

As illustrated above, whenever the assembly stations are in a different location of the embarkation stations, the signing system should include egress route identification signs marking unambiguously the evacuation route from the assembly stations to the embarkation stations. This should be done with the adequate survival craft directional signs.

					(mm) 300x100 400x120
		S 03 89	S 03 90		
					
S 03 91	S 03 92	S 03 93	S 03 94		
					
S 03 95	S 03 96	S 03 97	S 03 98		

# Escape route signs

## Deck and Stair identification signs



(mm)  
300x100  
400x150  
600x200



## Number and letter supplementary signs for marking life-saving appliances and for other identification requirements

(mm)  
75x150  
100x200  
150x300  
200x400



...



...



## Escape route signs according to ISO 24409 and EN ISO 7010

Escape route signs take priority over any other signs. These should be installed at consistent intervals of up to 15m in order to make it easier for evacuees to predict the location of the next evacuation sign.

Escape route signs should be installed at the center line over the doors at a height between 2.0m and 2.5m from the deck to the base of the sign in order to assure visibility from any foot traffic area. The escape route signs that are to be installed on bulkheads should be installed between 1.5m and 2.0m. As far as it is possible, installation heights should be kept throughout the escape route.

(mm)  
300x150  
400x200  
600x300



S 04 21



S 04 22



S 04 23



S 04 24



S 04 25



S 04 26



S 04 27



S 04 28



S 04 29



S 04 30

# Escape route signs





## Escape route signs according to ISO 24409 and EN ISO 7010













					(mm) 300x100 400x150 600x200
		S 04 35	S 04 36		
					
S 04 37	S 04 38	S 04 39	S 04 40		
					
S 04 41	S 04 42	S 04 43	S 04 44		
					
S 04 45	S 04 46	S 04 47	S 04 48		

							(mm) 300x150
S 04 51	S 04 52	S 04 53	S 04 54	S 04 55	S 04 56		

						(mm) [*]150x150 [*]200x200 300x300 400x400
	S 04 61	S 04 62	S 04 63	S 04 64		
						[*] Only available in this size
S 04 65	S 03 64	[*] S 04 67	S 03 65	S 03 66	S 03 67	

## Escape route signs for people with reduced mobility

					(mm) 150x150 [*]150x200 200x200 [*]200x300 300x300
S 04 71	S 04 72	[*] S 04 75	[*] S 04 76		[*] Only available in this size

				(mm) [*]300x100 300x150 [*]400x150 400x200 [*]600x200 600x300
[*] S 04 91	[*] S 04 92	[*] S 04 93		
				
S 04 81	S 04 82	S 04 83	S 04 84	
				[*] Only available in this size
S 04 85	S 04 86	S 04 87	S 04 88	

# Escape route signs

## Escape door mechanism signs

(mm)  
70x200  
100x240(\*)  
100x300



S 05 01



S 05 02



(\*) S 05 05



(\*) S 05 06



(\*) Only available in this size

(mm)  
300x150  
400x200  
600x300

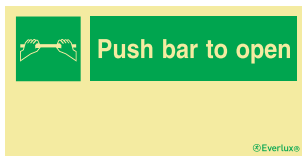

S 05 11

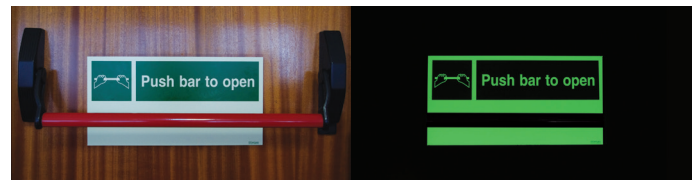

(mm)  
200x70(\*)  
300x100  
400x120  
600x200(\*\*)



(\*) S 05 15

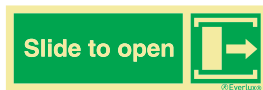

(\*) S 05 16

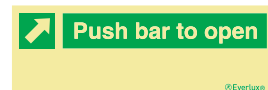

(\*\*) S 05 17



(\*) S 05 18



(\*) S 05 19

(\*) (\*\*)  
Also available in this size

(mm)  
200x50  
300x70  
400x100

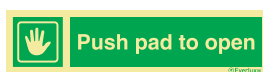

S 05 25

(mm)  
100x100(\*)  
150x150  
200x200  
300x300  
400x400(\*\*)

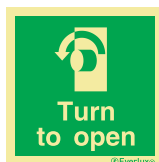

(\*) S 05 31

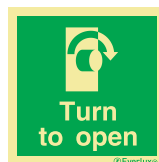

(\*) S 05 32

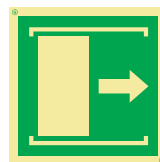

(\*\*) S 05 33

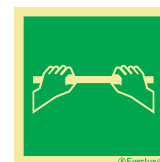

(\*\*) S 05 34



(\*\*) S 05 35

(\*) (\*\*)  
Also available in this size

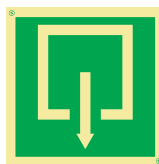

(\*\*) S 05 36



(\*\*) S 05 37



S 05 38



S 05 39

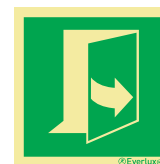

S 05 40



S 05 41

(mm)  
200x70  
300x100  
400x120



S 05 51



S 05 52



S 05 53



S 05 54

(mm)  
150x200  
200x300  
300x400



S 05 61



S 05 62



S 05 63



S 05 64

## IMO fire control signs - according to IMO Resolution A.654 (16)



Safety and operating instructions for trained personnel (SIS) - As per ISO 24409, SIS signs are safety-related signs that replicate the symbols used in the Fire Control Plans and are used to provide safety and operational instructions for trained personnel that can be either crew members or external personnel that may need to come on-board.



(mm)  
150x150  
200x200



S 10 01  
Fire control plan

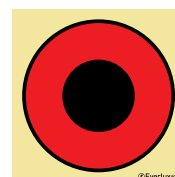

S 10 02  
Push-button/switch for fire alarm

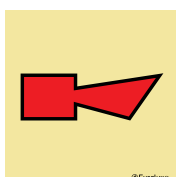

S 10 03  
Horn fire alarm

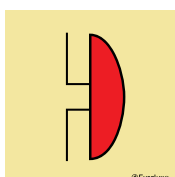

S 10 04  
Bell fire alarm

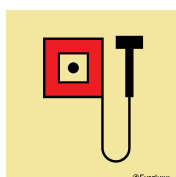

S 10 05  
Manually operated call point



S 10 06  
Space protected by automatic fire alarm

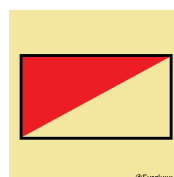

S 10 07  
Fire alarm panel

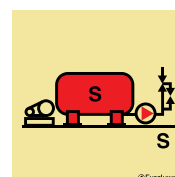

S 10 08  
Sprinkler installation

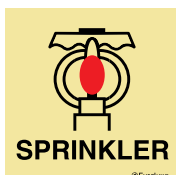

S 10 09  
Space protected by sprinkler

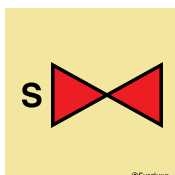

S 10 10  
Sprinkler section valve

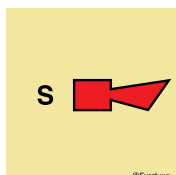

S 10 11  
Sprinkler horn

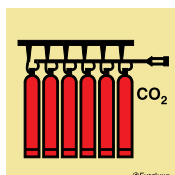

S 10 12  
CO<sub>2</sub> battery

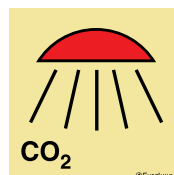

S 10 13  
Space protected by CO<sub>2</sub>

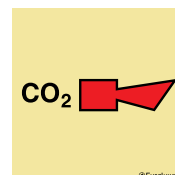

S 10 14  
CO<sub>2</sub> horn

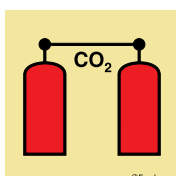

S 10 15  
CO<sub>2</sub> release station



S 10 16  
Halon 1301 battery



S 10 17  
Space protected by halon 1301

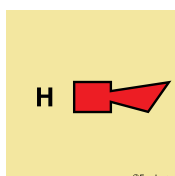

S 10 18  
Halon horn

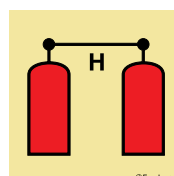

S 10 19  
Halon release station

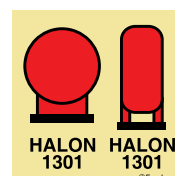

S 10 20  
Halon 1301 bottles placed in protected area

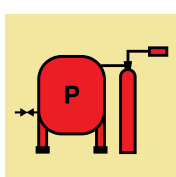

S 10 21  
Powder installation

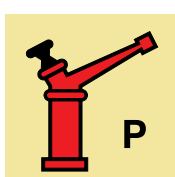

S 10 22  
Powder monitor (gun)

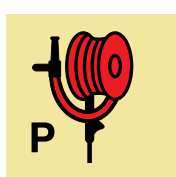

S 10 23  
Powder hose and handgun

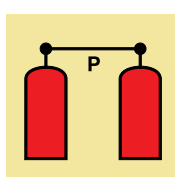

S 10 24  
Powder release station

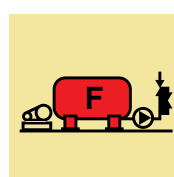

S 10 25  
Foam installation

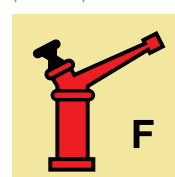

S 10 26  
Foam monitor (gun)

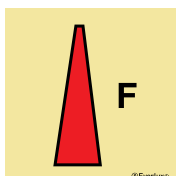

S 10 27  
Foam nozzle

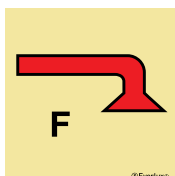

S 10 28  
Space protected by foam

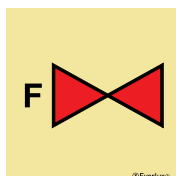

S 10 29  
Foam valve

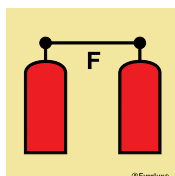

S 10 30  
Foam release station



S 10 31  
Hose box with spray/jet fire nozzle

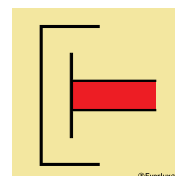

S 10 32  
International shore connection

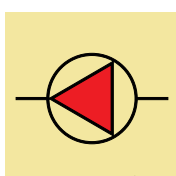

S 10 33  
Fire pump

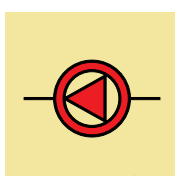

S 10 34  
Emergency fire pump

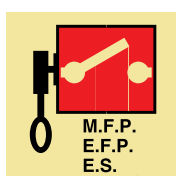

S 10 35  
Remote control fire pumps or emergency switches

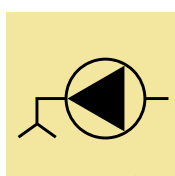

S 10 36  
Bilge pump

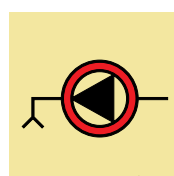

S 10 37  
Emergency bilge pump

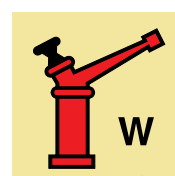

S 10 38  
Water monitor (gun)



## IMO fire control signs - according to IMO Resolution A.654 (16)

(mm)  
150x150  
200x200





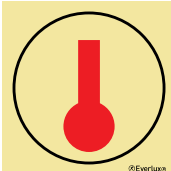
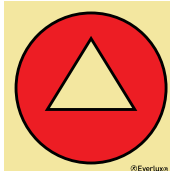
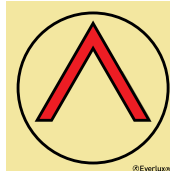
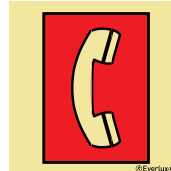
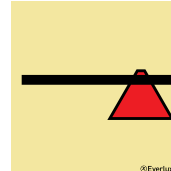

S 10 39 Water fog applicator	S 10 40 Drenching installation	S 10 41 Fire mains with fire valves	S 10 42 Section valves drenching system	S 10 43 Powder portable fire extinguisher - 6Kg	S 10 44 Foam portable fire extinguisher - 9L
S 10 45 Halon 1211 portable fire extinguisher - 4Kg	S 10 46 CO <sub>2</sub> portable fire extinguisher - 2Kg	S 10 47 Powder fire extinguisher - 2Kg	S 10 48 Powder fire extinguisher - 1Kg	S 10 49 Powder wheeled fire extinguisher - 50Kg	S 10 50 CO <sub>2</sub> wheeled fire extinguisher - 30Kg
S 10 51 Fire damper in vent duct	S 10 52 Fire station	S 10 53 Locker with fireman's outfit	S 10 54 Locker with additional breathing apparatus	S 10 55 Locker for protective clothing	S 10 56 Primary means of escape
S 10 57 Secondary means of escape	S 10 58 Space protected by drenching system	S 10 59 A class division	S 10 60 B class division	S 10 61 Remote controlled skylights	S 10 62 Remote controlled fuel/lubricating oil valves
S 10 63 Control station	S 10 64 Portable foam applicator	S 10 65 Inert gas installation	S 10 66 High expansion foam supply trunk	S 10 67 CO <sub>2</sub> / nitrogen bulk installation	S 10 68 Emergency generator
S 10 69 A class fire door	S 10 70 A class sliding fire door	S 10 71 A class fire door self-closing	S 10 72 A class sliding door self-closing	S 10 73 B class fire door	S 10 74 B class sliding fire door
S 10 75 B class fire door self-closing	S 10 76 B class sliding fire door self-closing	S 10 77 Closing appliance for exterior ventilation inlet or outlet	S 10 78 Emergency switchboard	S 10 79 Remote ventilation shut off	S 10 80 Main vertical zone

## IMO fire control signs - according to IMO Resolution A.654 (16)

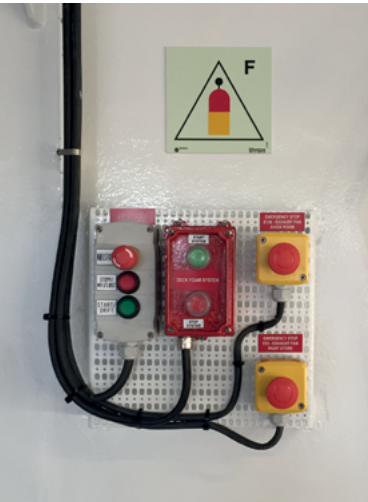
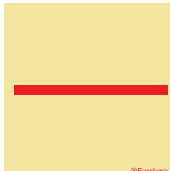
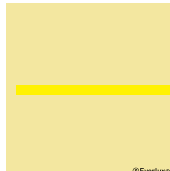
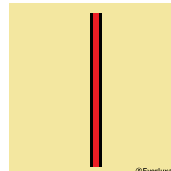
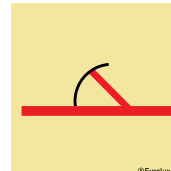
							(mm) 150x150 200x200
S 10 81 Smoke detector	S 10 82 Heat detector	S 10 83 Gas detector	S 10 84 Flame detector	S 10 85 Emergency telephone station	S 10 86 Fire axe		

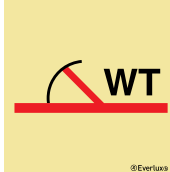
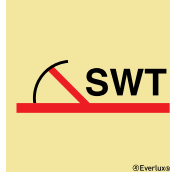
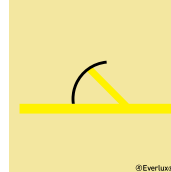
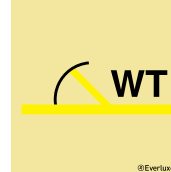
## IMO fire control signs - according to IMO Resolution A.952 (23), ISO 17631 and ISO 24409

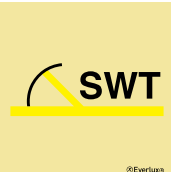
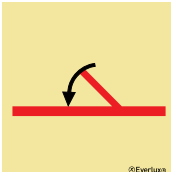
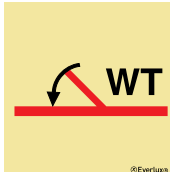
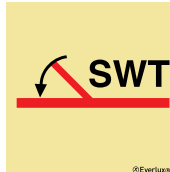
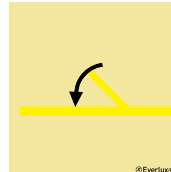
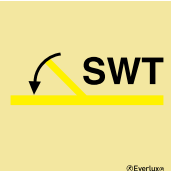
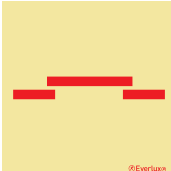
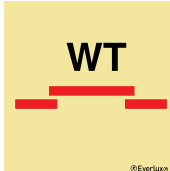
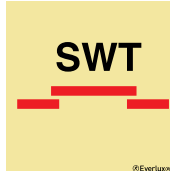
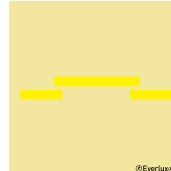
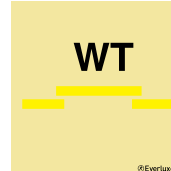
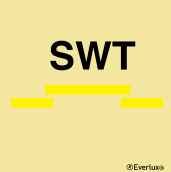
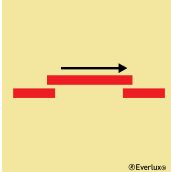
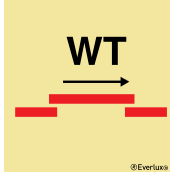
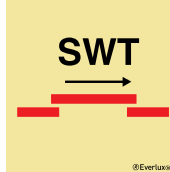
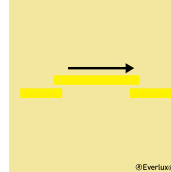
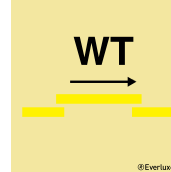
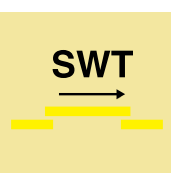
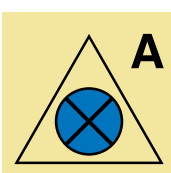
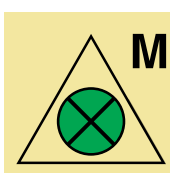
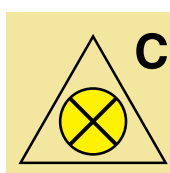
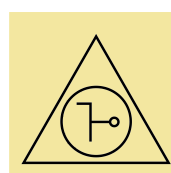
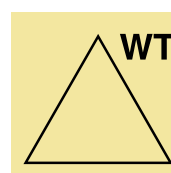
						(mm) 150x150 200x200
	S 12 01 A-class division	S 12 02 B-class division	S 12 03 Main vertical zone	S 12 04 A-class hinged fire door		
						
	S 12 05 A-class watertight fire door	S 12 06 A-class semi-watertight fire door	S 12 07 B-class hinged fire door	S 12 08 B-class watertight fire door		
						
S 12 09 B-class semi-watertight fire door	S 12 10 A-class hinged self-closing fire door	S 12 11 A-class watertight self-closing fire door	S 12 12 A-class semi-watertight self-closing fire door	S 12 13 B-class hinged self-closing fire door	S 12 14 B-class watertight self-closing fire door	
						
S 12 15 B-class semi-watertight self-closing fire door	S 12 16 A-class sliding fire door	S 12 17 A-class watertight sliding fire door	S 12 18 A-class semi-watertight sliding fire door	S 12 19 B-class sliding fire door	S 12 20 B-class watertight sliding fire door	
						
S 12 21 B-class semi-watertight sliding fire door	S 12 22 A-class self-closing sliding fire door	S 12 23 A-class self-closing watertight sliding fire door	S 12 24 A-class self-closing semi-watertight sliding fire door	S 12 25 B-class self-closing sliding fire door	S 12 26 B-class self-closing watertight sliding fire door	
						
S 12 27 B-class self-closing semi-watertight sliding fire door	S 12 28 Ventilation remote control shut-off for accommodation and service spaces	S 12 29 Ventilation remote control shut-off for machinery spaces	S 12 30 Ventilation remote control shut-off for cargo spaces	S 12 31 Remote control for skylight	S 12 32 Remote control for watertight doors	

## IMO fire control signs - according to IMO Resolution A.952 (23), ISO 17631 and ISO 24409

(mm)  
150x150  
200x200

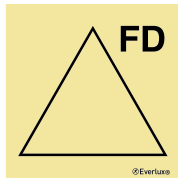

S 12 33  
Remote control for fire doors

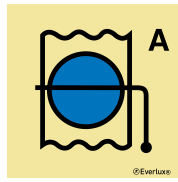

S 12 34  
Fire damper for accommodation and service spaces

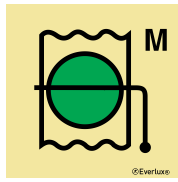

S 12 35  
Fire damper for machinery spaces

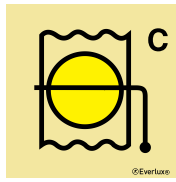

S 12 36  
Fire damper for cargo spaces

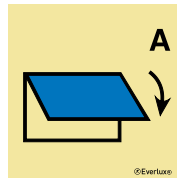

S 12 37  
Closing device for ventilation inlet or outlet for accommodation and service spaces

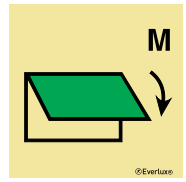

S 12 38  
Closing device for ventilation inlet or outlet for machinery spaces

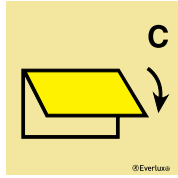

S 12 40  
Closing device for ventilation inlet or outlet for cargo spaces

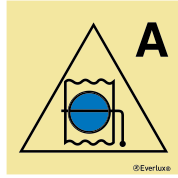

S 12 41  
Remote control for fire damper(s) for accommodation and service spaces

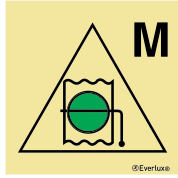

S 12 42  
Remote control for fire damper(s) for machinery spaces

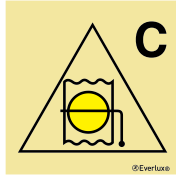

S 12 43  
Remote control for fire damper(s) for cargo spaces

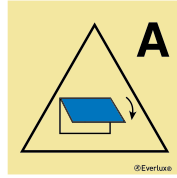

S 12 44  
Remote control for closing device(s) for ventilation inlet and outlet for accommodation and service spaces

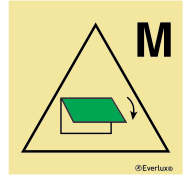

S 12 45  
Remote control for closing device(s) for ventilation inlet and outlet for machinery spaces

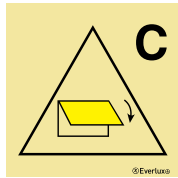

S 12 46  
Remote control for closing device(s) for ventilation inlet and outlet for cargo spaces



S 12 47  
Fire protection appliances or structural fire protection plan

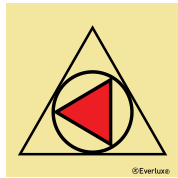

S 12 48  
Remote control for fire pump(s)

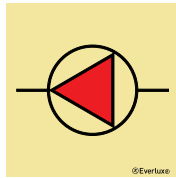

S 10 33  
Fire pump(s)

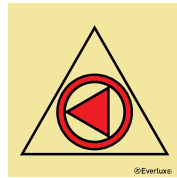

S 12 49  
Remote control for emergency fire pump or fire pump supplied by the emergency source of power

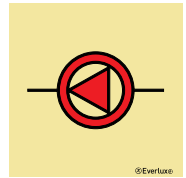

S 10 34  
Emergency fire pump

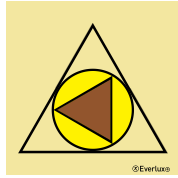

S 12 51  
Fuel pump(s) remote shut-off

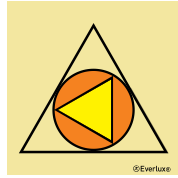

S 12 52  
Lube oil pump(s) remote shut-off

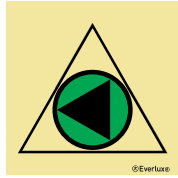

S 12 53  
Remote control for bilge pump(s)

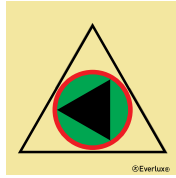

S 12 54  
Remote control for emergency bilge pump

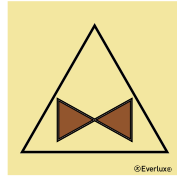

S 12 55  
Remote control for fuel oil valves

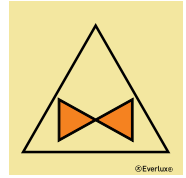

S 12 56  
Remote control for lube oil valves

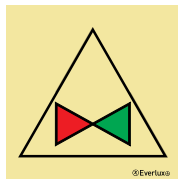

S 12 57  
Remote control for fire pump valve(s)

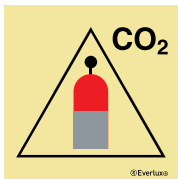

S 12 58  
CO<sub>2</sub> remote release station

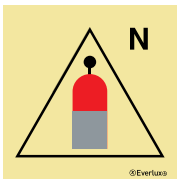

S 12 59  
Nitrogen remote release station

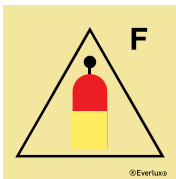

S 12 60  
Foam remote release station

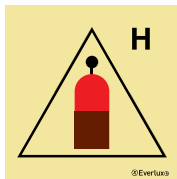

S 12 61  
Gas remote release station

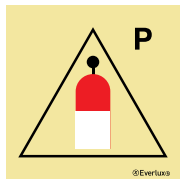

S 12 62  
Powder remote release station

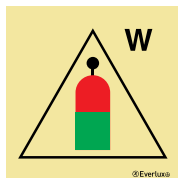

S 12 63  
Water remote release station

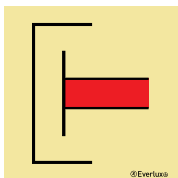

S 10 32  
International shore connection

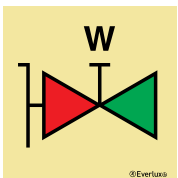

S 12 65  
Fire hydrant

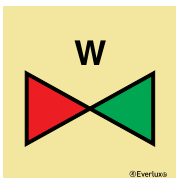

S 12 66  
Fire main section valve

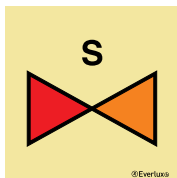



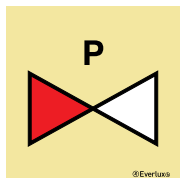











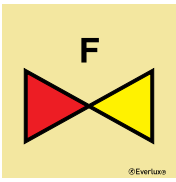
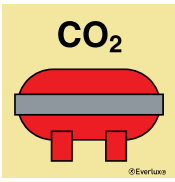
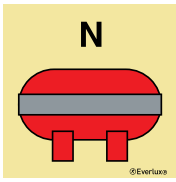
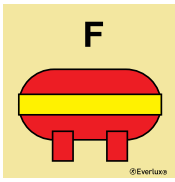
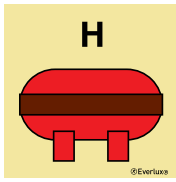
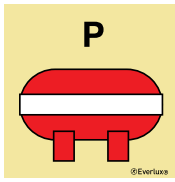
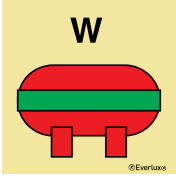
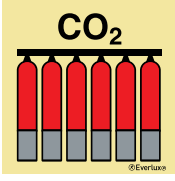
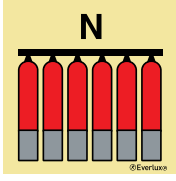
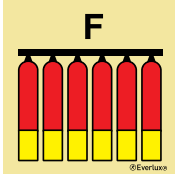
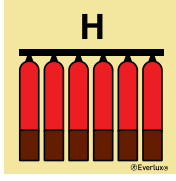
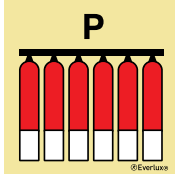
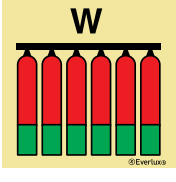
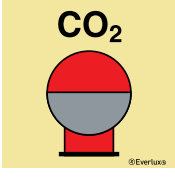
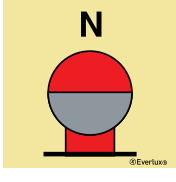
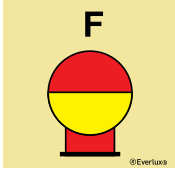
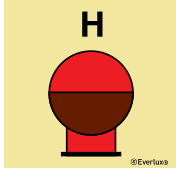
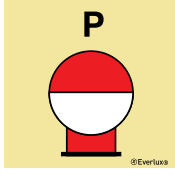
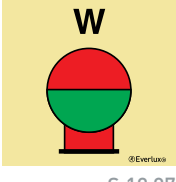
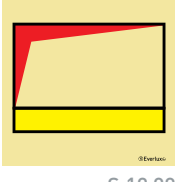
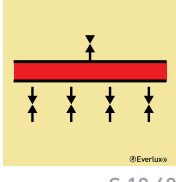

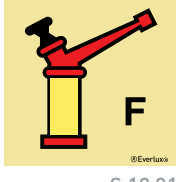
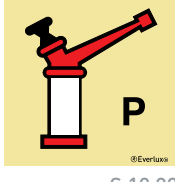
S 12 67  
Sprinkler-section valve

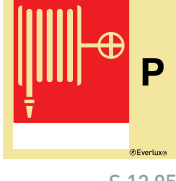

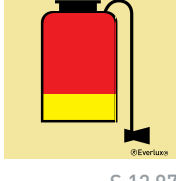
S 12 68  
Powder-section valve

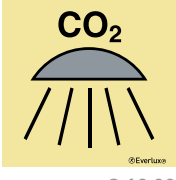
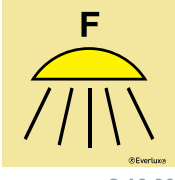
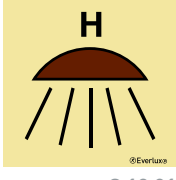
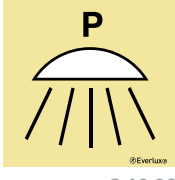
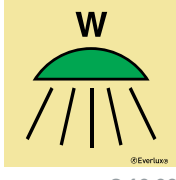
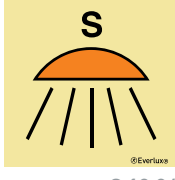
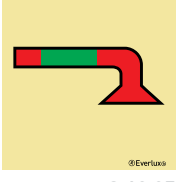
IMO fire control signs - according to IMO Resolution A.952 (23), ISO 17631 and ISO 24409

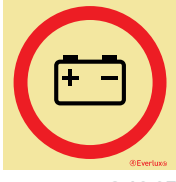
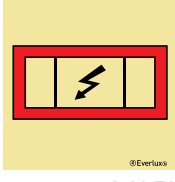
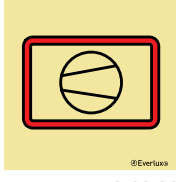
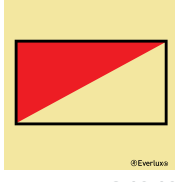
						     	(mm) 150x150 200x200
							
S 12 69 Foam-section valve	S 12 70 CO <sub>2</sub> fixed fire-extinguishing installation	S 12 71 Nitrogen fixed fire-extinguishing installation	S 12 72 Foam fixed fire-extinguishing installation	S 12 73 Gas fixed fire-extinguishing installation	S 12 74 Powder fixed fire-extinguishing installation		
							
S 12 75 Water fixed fire-extinguishing installation	S 12 76 CO <sub>2</sub> fixed fire-extinguishing battery	S 12 77 Nitrogen fixed fire-extinguishing battery	S 12 78 Foam fixed fire-extinguishing battery	S 12 79 Gas fixed fire-extinguishing battery	S 12 80 Powder fixed fire-extinguishing battery		
							
S 12 81 Water fixed fire-extinguishing battery	S 12 82 CO <sub>2</sub> fixed fire-extinguishing bottle, placed in protected area	S 12 83 Nitrogen fixed fire-extinguishing bottle, placed in protected area	S 12 84 Foam fixed fire-extinguishing bottle, placed in protected area	S 12 85 Gas fixed fire-extinguishing bottle, placed in protected area	S 12 86 Powder fixed fire-extinguishing bottle, placed in protected area		
							
S 12 87 Water fixed fire-extinguishing bottle, placed in protected area	S 12 88 High-expansion-foam supply trunk (outlet)	S 10 40 Water-spray-system valves	S 10 65 Inert gas installation	S 12 91 Foam monitor	S 12 92 Powder monitor		
							
S 12 93 Water monitor	S 12 94 Foam fire hose and nozzle	S 12 95 Powder fire hose and nozzle	S 12 96 Water fire hose and nozzle	S 12 97 Portable foam applicator unit or relevant spare tank(s)	S 12 98 Fire locker		
							
S 12 99 Spaces or group of spaces protected by CO <sub>2</sub> fire-extinguishing system	S 13 00 Spaces or group of spaces protected by foam fire-extinguishing system	S 13 01 Spaces or group of spaces protected by gas fire-extinguishing system	S 13 02 Spaces or group of spaces protected by powder fire-extinguishing system	S 13 03 Spaces or group of spaces protected by water fire-extinguishing system	S 13 04 Spaces or group of spaces protected by sprinkler or high pressure fire-extinguishing system		
							
S 13 05 Water fog applicator	S 13 68 Emergency source of electrical power (generator)	S 13 07 Emergency source of electrical power (battery)	S 10 78 Emergency switchboard	S 13 09 Air compressor for breathing devices	S 13 10 Control panel for fire detection and alarm system		

## IMO fire control signs - according to IMO Resolution A.952 (23), ISO 17631 and ISO 24409

(mm)  
150x150  
200x200

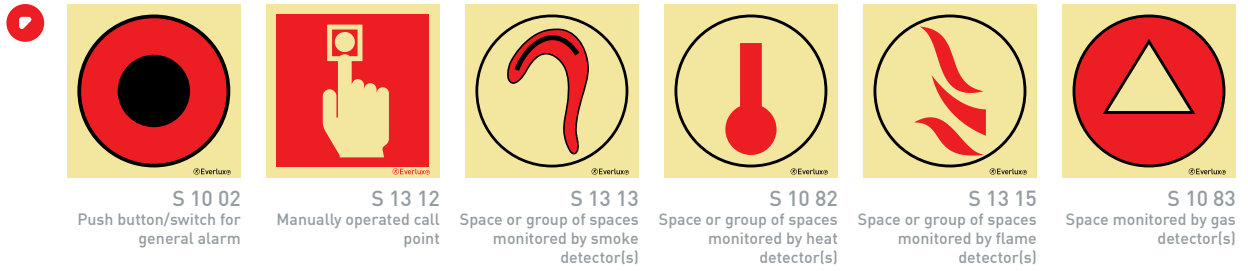

## IMO fire control signs - fire extinguisher according to IMO Resolution A.952 (23) and ISO 17631

(mm)  
150x150  
200x200

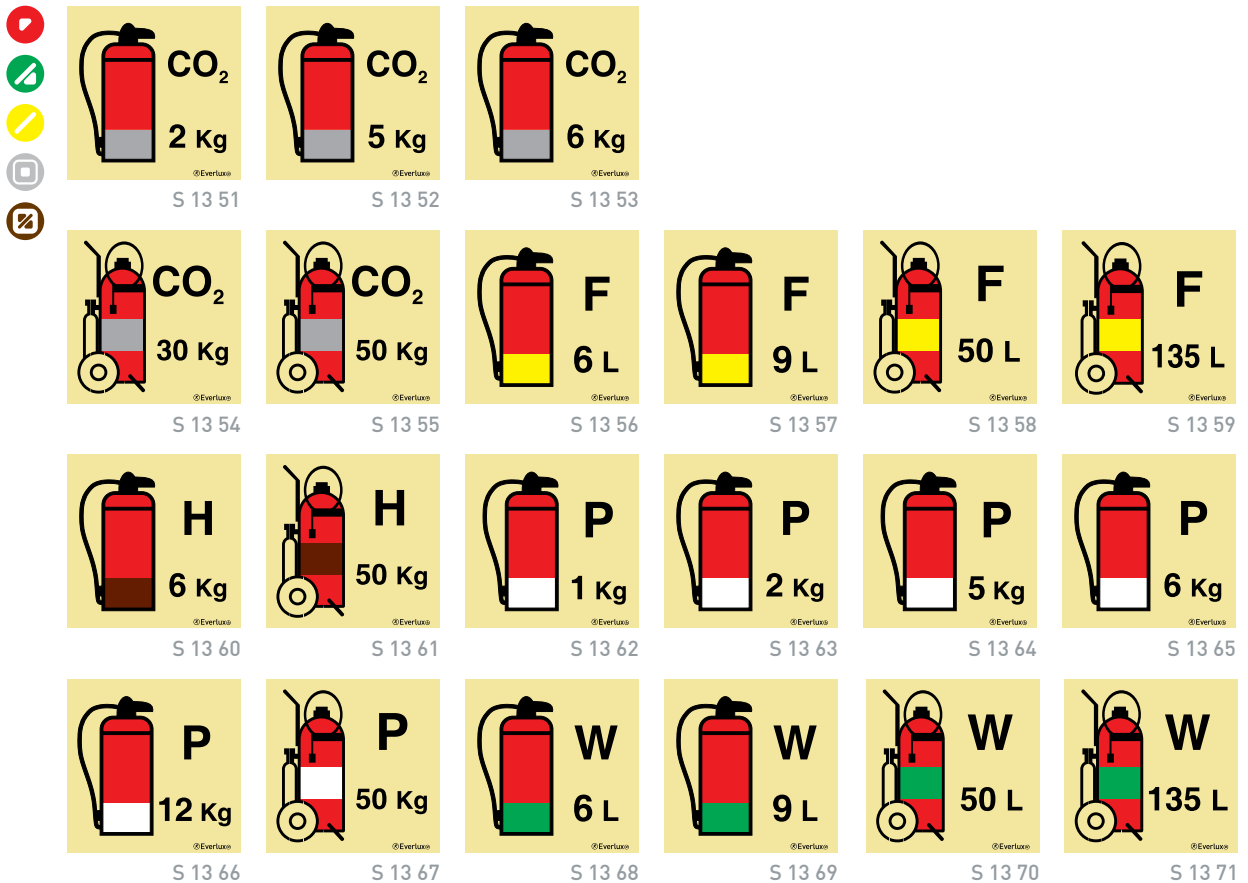

(mm)  
150x150  
200x200

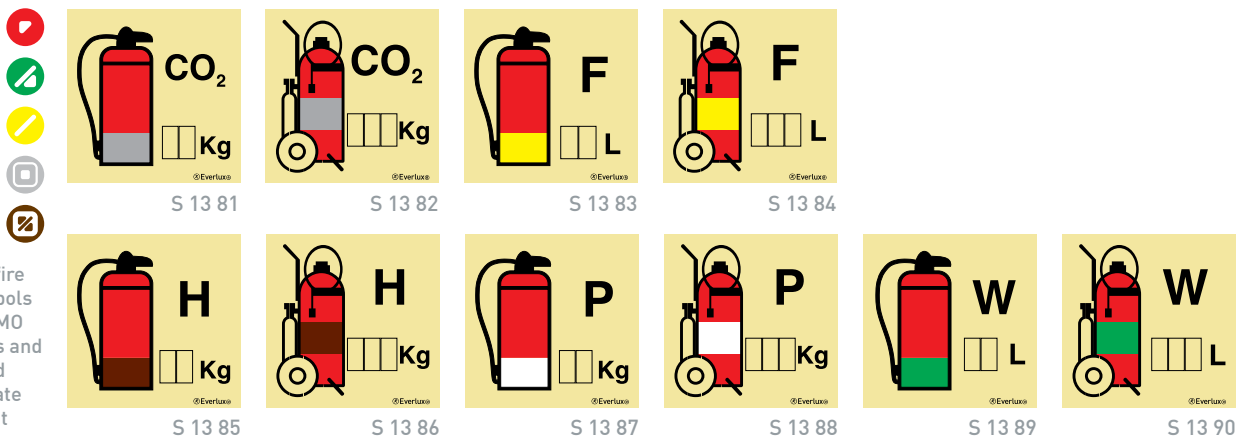

These signs with fire extinguisher symbols are according to IMO and ISO Standards and can be customized with the appropriate extinguisher agent capacity





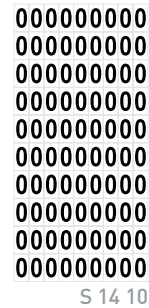

### IMO fire control signs - fire extinguisher according to IMO Resolution A.952 (23) and ISO 17631

These sheets are available in two different formats: one format contains the same digit and the other contains multiple digits. The sheets in single digit format are available with numbers 1 to 0. There are 90 numbers supplied on each sheet. The multiple digit sheet contains the most commonly used numbers in greater quantities and should allow the identification of up to 24 fire extinguishers.

(mm)  
15x28  
A4 page

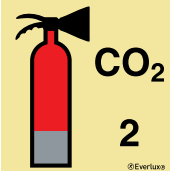
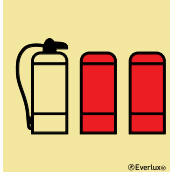

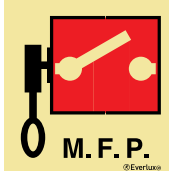
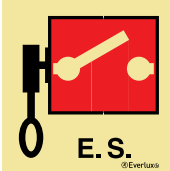
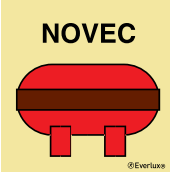
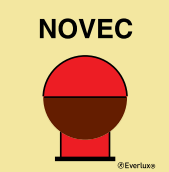
### Non-standard Fire Control IMO signs

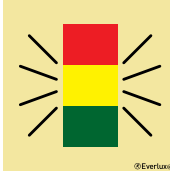
 S 14 51	 S 14 53	 S 14 54		(mm) 150x150 200x200			
 S 14 55	 S 14 56	 S 14 57			 S 14 58	 S 14 59	 S 14 60
 S 14 61	 S 14 70	 S 14 71			 S 14 72	 S 14 73	 S 14 74
 S 14 75	 S 14 76	 S 14 77			 S 14 78	 S 14 79	 S 14 80
 S 14 81	 S 14 82	 S 14 83	 S 14 84	 S 14 86	 S 14 85		

# Fire

## Fire-fighting equipment signs in compliance with ISO 24409 and EN ISO 7010



(mm)  
150x150  
200x200  
300x300



S 16 01



S 16 02

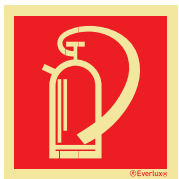

S 16 03

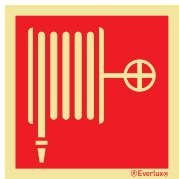

S 16 05



S 16 06



S 16 07



S 16 08

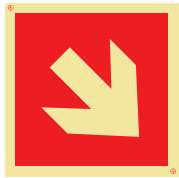

S 16 09

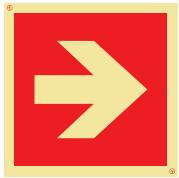

S 16 10



S 16 91



S 16 92



S 16 93



S 16 94



S 16 95



S 16 96



S 16 97



S 16 98



S 16 99

(mm)  
100x200  
150x300  
200x400



S 16 51



S 16 52



S 16 53



S 16 54



S 16 55

## Fire fighting equipment signs

(mm)  
100x300



S 16 85

To indicate when an extinguisher is missing a sign can be placed on the wall behind the extinguisher that displays the telephone number of the service agent or supplier

## Supplementary Signs, Combination Signs and Multiple Signs



Supplementary signs provide complementary information and will extend the safety message communicated by the referent of a given safety sign. There are supplementary explanatory signs, supplementary directional arrow signs and supplementary identification signs. When a safety sign is used in conjunction with a supplementary sign, that conjunction becomes a combination sign. The example on the left hand side uses a fire extinguisher sign together with several supplementary signs.



When a text supplementary sign is used then it should use the languages that are appropriate to the service of the ship and the working language on-board the vessel as illustrated in this example using a fire extinguisher identification supplementary sign with English and Russian text.

## Fire fighting equipment signs with supplementary text



## Numbers and other supplementary signs for marking fire fighting equipment and other identification requirements

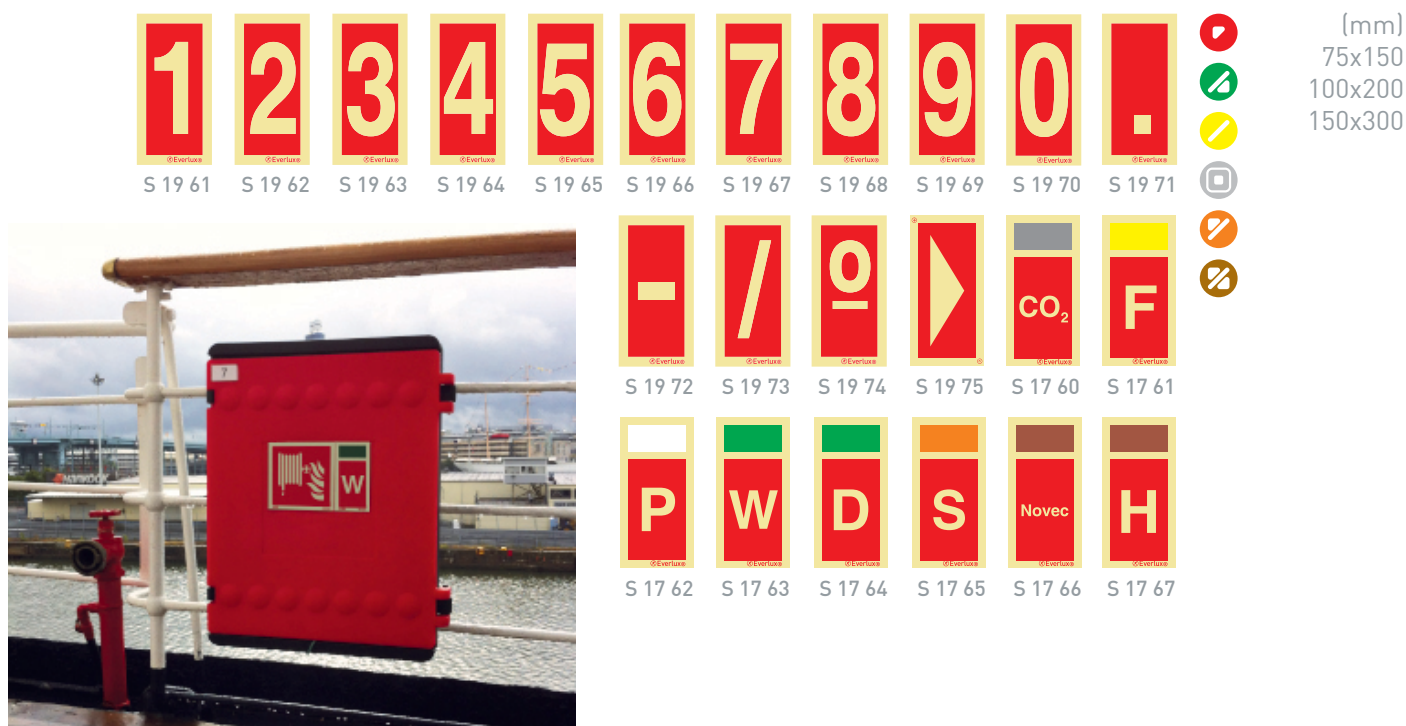

## Fire extinguisher identification signs

(mm)  
75x200

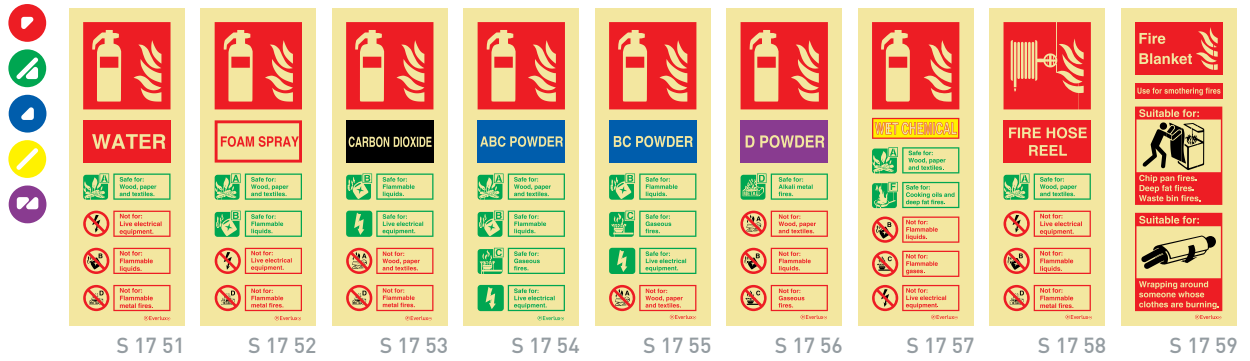

(mm)  
150x100  
200x150



## Numbered fire extinguisher identification signs

(mm)  
150x120





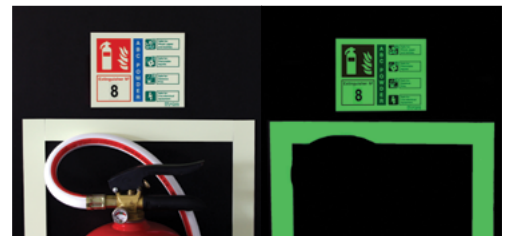
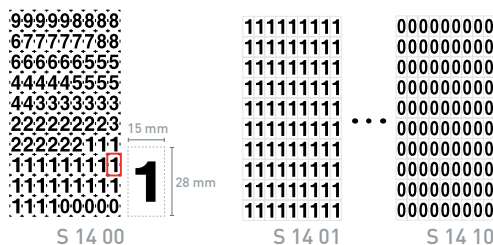

(mm)  
15x28  
A4 page

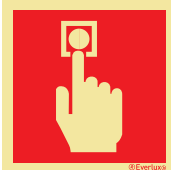

## Fire alarm signs

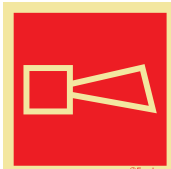

			▶ (mm) 150x150 200x200 300x300
	S 13 12	S 18 02	
			
S 18 03	S 18 04	S 18 05	
			
S 18 06	S 18 07	S 18 08	

			▶ (mm) 150x200 200x300 300x400
S 18 21	S 18 22	S 18 23	
			
S 18 21	S 18 22	S 18 23	

## Signs for lifts

					▶ (mm) 150x200 200x300
S 18 41	S 18 42	S 18 43	S 18 44	S 18 45	
					
S 18 46	S 18 47	S 18 48	S 18 49	S 18 50	

## Signs with supplementary text

(mm)  
200x70(\*)  
300x100  
400x120

(\*) Also available  
in this size

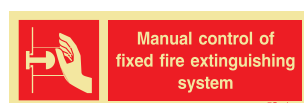
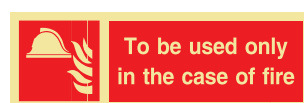
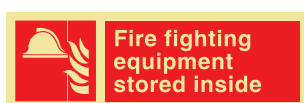
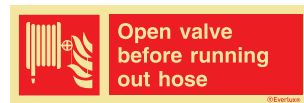
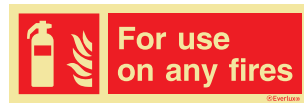

## Low Location Lighting system

The spreading of smoke is one of the most dangerous consequences of a fire rendering evacuation difficult and in some cases impossible. Under these conditions, visibility is reduced causing panic and increasing the evacuation time which is a critical factor in avoiding intoxication which can lead to death.

The  Everlux® Low Location Lighting (LLL) system is a unique system that allows all evacuation routes to stay illuminated, thereby communicating a clear, continuous and unambiguous “means of escape” message which leads to a safe place. The locations of fire fighting equipment are also clearly marked as part of the system along the escape routes.

This LLL system is unique in providing consistent and regular information throughout the complete escape route. This reduces possible confusion and panic, factors that hamper the safe egress from occupied areas.

According to IMO Resolution A. 752 (18) all means of egress must be marked with Low Location Lighting system at all points of the evacuation route. The LLL system is also recommended by ISO Standards, namely ISO 15370.

The illustration below depicts a complete safety signage system installed on board:



**A** - Photoluminescent signs installed at a high location level (above 2m) are to be visible and identified from further distances.

**B** - Photoluminescent signs installed at an intermediate location level. Per ISO 24409 fire-fighting equipment signs shall be installed either directly on the fire-fighting equipment or as close as practicable.

Recommended range for signs with text providing information and/or instructions to the user.

**C** - Photoluminescent signs at a low location level (within 30cm from deck according to SOLAS 2004 Chapter II Regulation 13.3.3.5 and ISO 15370): a sign system that illuminates the entire escape route and identifies the location of fire fighting equipment at floor level.

The components of the  Everlux® Low Location Lighting system are:

- Photoluminescent rigid plastic strips and signs to be applied on walls.

- Floor marking strips: 0.3mm thick non-slip photoluminescent self-adhesive marking strips and signs to be applied directly to the floor.

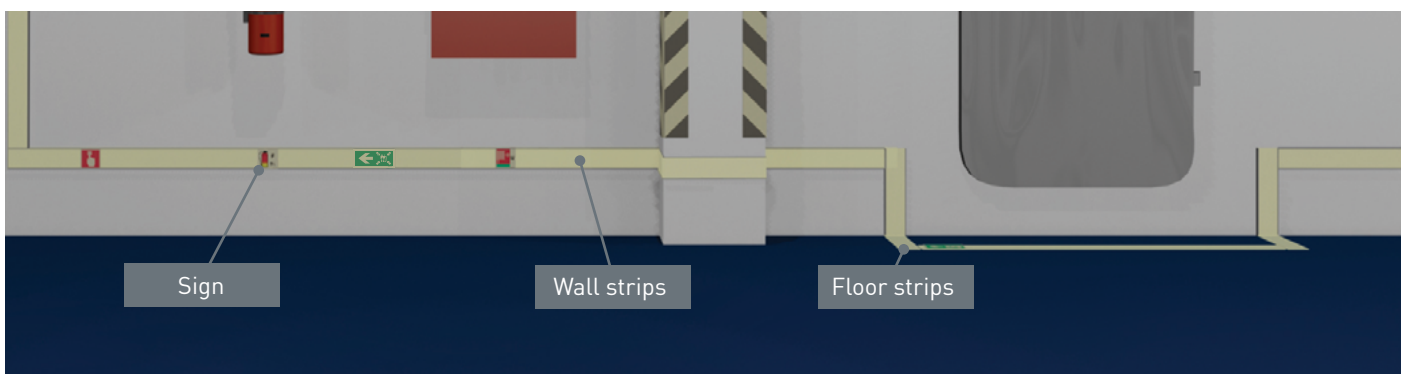



# Low Location Lighting

## Example

Escape doors must be signed as illustrated.



Stairs and corridors which are 2m wide or more should be fitted with LLL photoluminescent strips on both sides.



Photoluminescent directional signs must be placed at each change of level.

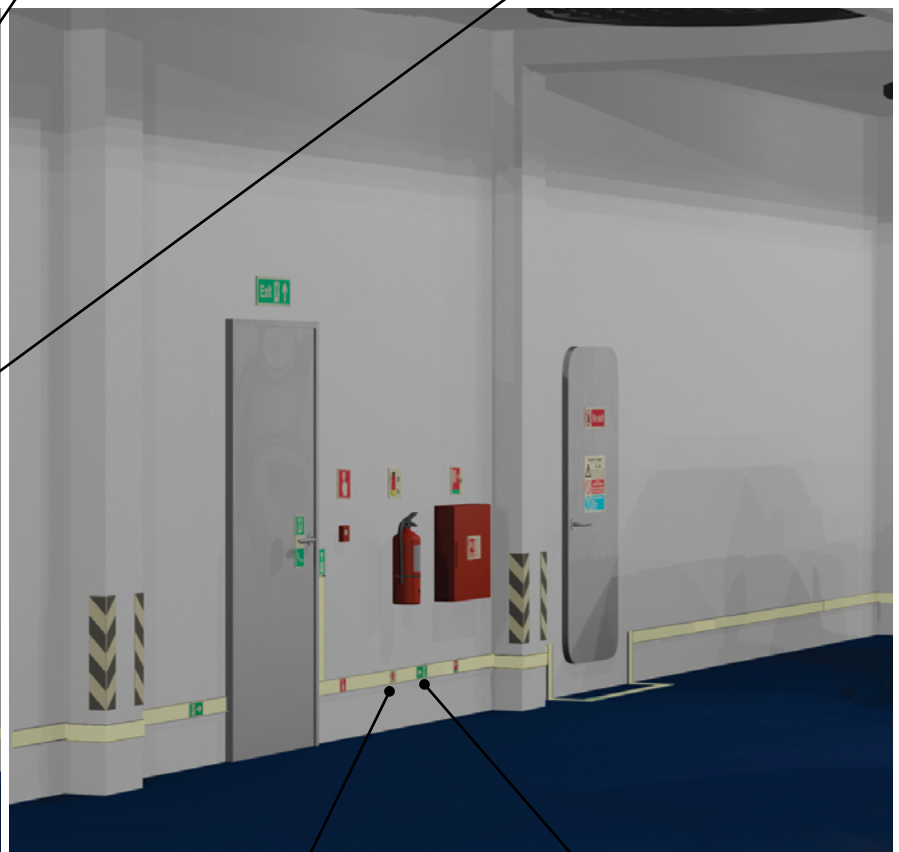
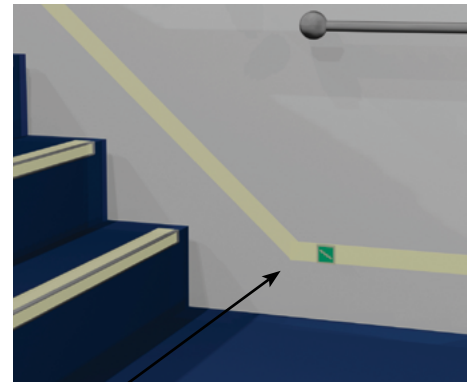

Non-escape doors must be signed as illustrated.

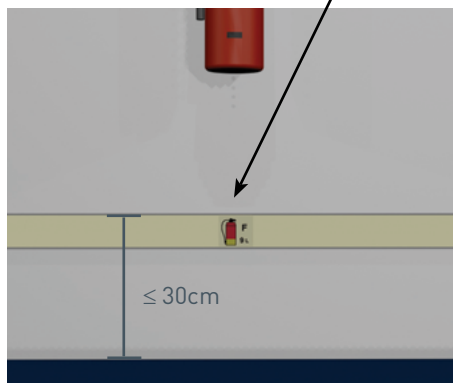

According to Solas 2004 Chapter II Regulation 13.3.3.5 and IMO Resolution A.752 (18) photoluminescent marking strips must be placed not more than 30cm above the deck at all points of the escape route.

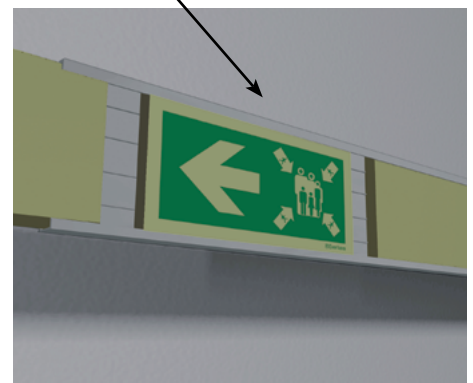

Directional escape route signs complement the continuous photoluminescent strip installed in aluminium rail.

## Normative and legal framework, technical performances and properties

Guidance systems at floor level (Low Location Lighting) began with legislation covering the areas of greatest risk. Firstly in aviation with FAA in 1984 and then in the maritime industry with IMO Regulations in 1989.

Since 1999, following the development of new photoluminescent technologies, other authorities have begun the process of standardising these systems.

Important Standards	IMO Resolution A.752 (18)	Guidelines for the evaluation, testing and application of low-location lighting on passenger ships
	SOLAS Convention 2004	Means of escape - Marking of escape routes
	European Directive 2002/25/EC	Safety rules and standards for passenger ships
	ISO 15370	Low Location Lighting (LLL) on passenger ships
	ISO 16069	SWGS - Safety Way Guidance Systems
	ISO 3864	Graphical symbols - safety colours and safety signs

### Ⓢ Everlux® Low Location Lighting Strip and Sign System:

The strip and sign system can be mounted directly to walls using the Ⓢ Everlux® adhesive or with the aluminium frames.

According to IMO A.752 (18) his system shall be positioned in the following way, throughout the escape routes:

- Where a corridor has a width of 2m or more the guidance line shall be applied continuously on both sides of the corridor.
- Where the width is less than 2m, one guidance line may be sufficient and should be as continuous as possible on the side where the fire fighting equipment is located. If there is no fire fighting equipment the strips should be applied continuously on the side that leads to the door handle.
- The strips should not be installed more than 30cm above deck.

### Ⓢ Everlux®-LLL Strip and Sign System for Floors and Stairs:

The strip and sign system can be placed directly onto floors and stairs using the integral high adherence adhesive. Simply remove the backing material and position accurately.

Luminance Properties			
Applicable Resolutions and Standards/ Product	Luminance Intensity (mcd/m <sup>2</sup> ) (After removing the exciting light)		Period of Light Decay Luminance Intensity greater than a 0.3 mcd/ m <sup>2</sup>
	10 minutes	60 minutes	
IMO Resolution A.752(18) a)	15 mcd/m <sup>2</sup>	2.0 mcd/m <sup>2</sup>	...
ISO 15370 a)	15 mcd/m <sup>2</sup>	2.0 mcd/m <sup>2</sup>	...
Ⓢ Everlux® a)	40 mcd/m <sup>2</sup>	8 mcd/m <sup>2</sup>	1800 minutes
Ⓢ Everlux®-LLL b)	80 mcd/m <sup>2</sup>	10 mcd/m <sup>2</sup>	1000 minutes

a) Values obtained with a stimulation of only 25 lux, during 24 hours with a fluorescent lamp with colour temperature of 4000K, according to ISO 15370 measurement protocol.

b) Values obtained with a stimulation of only 25 lux, during 15 minutes with a fluorescent lamp with colour temperature of 6500K, according to ISO 16069 measurement protocol.

All signs have a high photoluminescent intensity which is achieved with as little as a 25 lux charge from an ambient light source

### Base Materials:

**Signs and strips for wall mounting:** Photoluminescent rigid plastic 1.2mm thick; photoluminescent self-adhesive vinyl;

**Signs and strips for floors and stairs:** Photoluminescent non-slip self-adhesive polycarbonate 0.3mm thick;

Transparent vinyl signs are also available to complement the Ⓢ Everlux® Low Location Lighting system.

**Printing:** Serigraphy, high gloss paint with a high UV resistance.

**Chemical Characteristics:** Non-phosphorous, non-radioactive, lead-free and non-poisonous.



## Turnkey safety signage projects

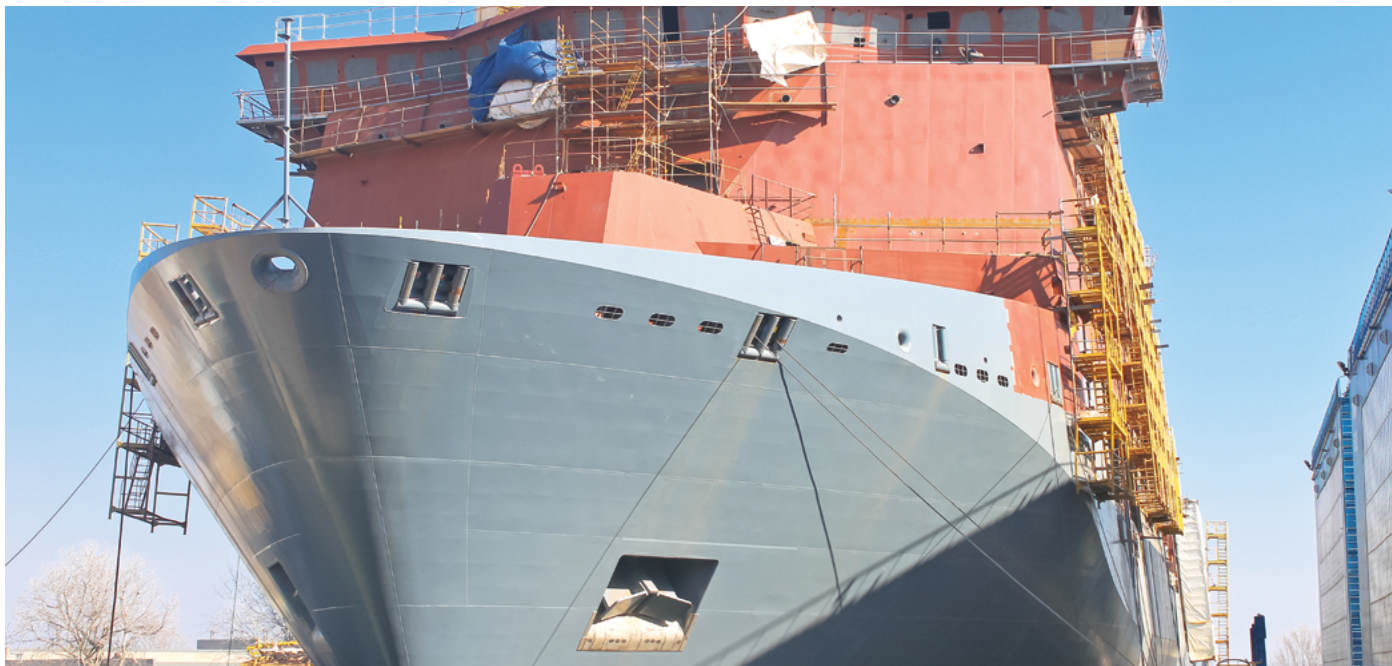

Ⓢ Everlux® adopts an integrative approach to every safety signage project the company is involved with from project development through to installation and project delivery. When hiring Ⓢ Everlux® for a turnkey safety signage project, customers benefit from a high quality on time service which includes on-board and remote surveys, life-safety and fire control plan and Low Location Lighting project development using the Ⓢ Everlux® Project maritime tool, supply, installation, on-board luminance measurements, project management, documentation and delivery.

The Ⓢ Everlux® turnkey safety signage project service is the ideal solution for owners, shipyards or marine outfitters who are involved with new-build or major refurbishment on vessels or oil rigs.



## Photoluminescent low location lighting system inspections and measurement service

Ⓢ Everlux® has the Approval as Service Supplier by DNV for photoluminescent Low Location Lighting measurements. Our technicians are available worldwide to help you meet the classification bodies' requirements in a fast and cost-effective way.

The inspection and measurement reports on photoluminescent LLL systems are mandatory according to IMO Resolution A.752 (18), adopted on 4 November 1993. These guidelines cover the approval, installation and maintenance of low location lighting (LLL) required by regulations II-2/28, paragraph 1.10 and II-2/41-2, paragraph 4.7 of the 1974 SOLAS Convention, as amended, on all passenger ships carrying more than 36 passengers, to readily identify the passengers' route of escape when the normal emergency lighting is less effective due to smoke.

According to IMO Resolution A.752 (18), chapter 9, a maintenance of LLL systems should be visually examined and checked once a week and a record kept. All missing, damaged or inoperable LLL components should be replaced.

All LLL systems should have their luminance tested at least once every five years.

Readings should be taken on site. If the luminance for a particular reading does not meet the requirement of these guidelines, readings should be taken in at least ten locations equally spaced apart in the space. If more than 30% of the readings do not meet the requirements of these guidelines, the entire LLL system should be replaced.

If between 20% and 30% of the readings do not meet the requirements of these guidelines, the LLL system should be checked again in one year or may be replaced.

For detailed information on the Ⓢ Everlux® turnkey safety signage project service or on the mandatory requirements, inspection and measurement reports of photoluminescent LLL systems, please contact us at [commercial@everluxmaritime.com](mailto:commercial@everluxmaritime.com).

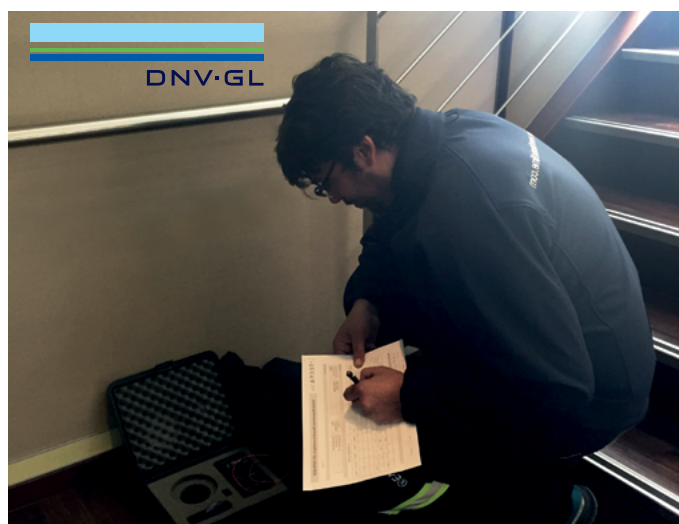

## Ⓢ Everlux® project maritime

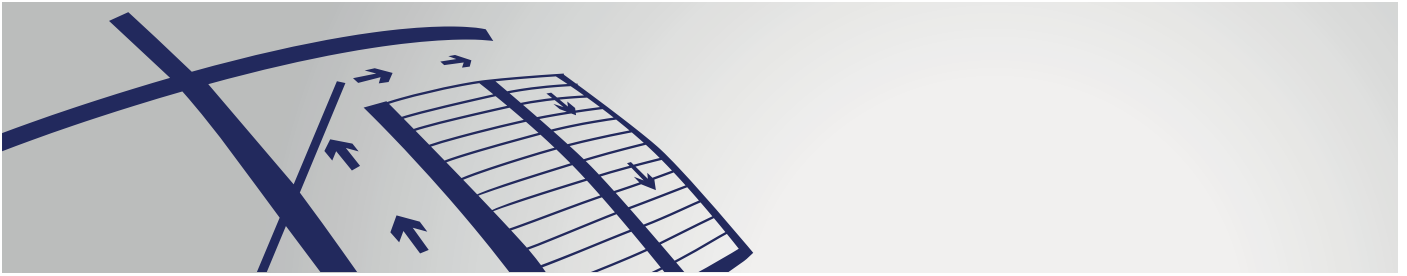

Ⓢ Everlux® project maritime is a software support tool for the development of safety signage and Low Location Lighting (LLL) projects and respective bill of quantities. This tool facilitates the most adequate selection of safety signs and provides installation companies with the right technical documentation to assure that the safety signs that are projected will be installed onboard simultaneously reducing the installation time.

Ⓢ Everlux® project maritime is available in two different versions: version 2.5 and version 2.5i. In terms of hardware both versions can be used with 64 bit processors. The 2.5 version works on AutoCAD (post 2008 versions except AutoCAD LT) and after its installation will automatically generate a tool bar with the Ⓢ Everlux® project maritime menu.

The 2.5i version is an independent application that allows the use of image files (type \*.dxf; \*.jpg; \*.bmp; \*.png) as the basis for the safety signage project.

Ⓢ Everlux® project maritime is available for free download at: [www.everluxmaritime.com/en/downloads](http://www.everluxmaritime.com/en/downloads)

## Quick life-safety and fire control plan development

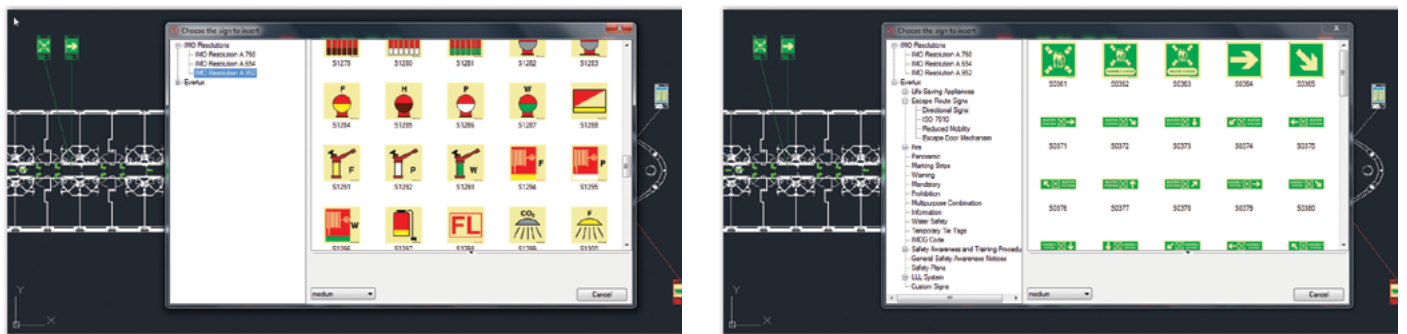

## Quick Low Location Lighting project development and automated BOQ creation

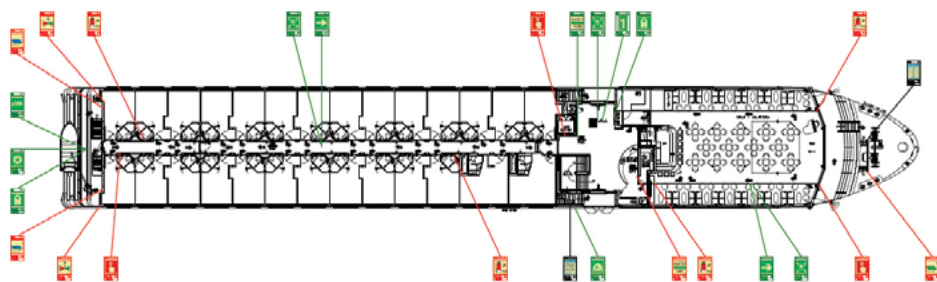
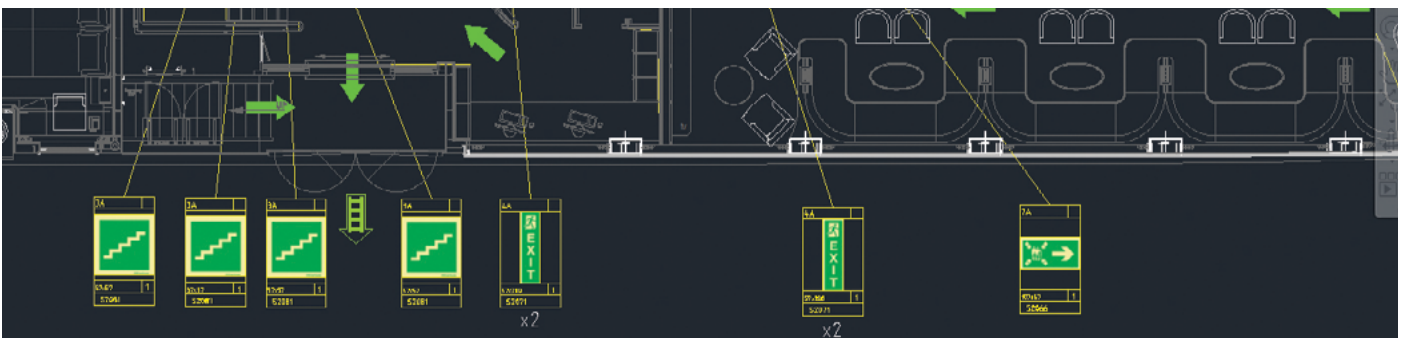



# Low Location Lighting

## Signs for wall marking at floor level

(mm)  
107x57  
158x83

The signs featured in this page can be supplied in photoluminescent rigid plastic, self-adhesive photoluminescent vinyl and transparent self-adhesive vinyl signs. The transparent self-adhesive vinyl signs are a quick solution to complement Low Location Lighting systems by applying them directly on to the photoluminescent strips.

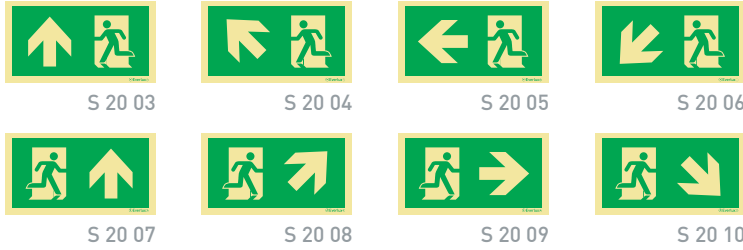

Escape route signs with symbols according to ISO 7010 and BS 5499

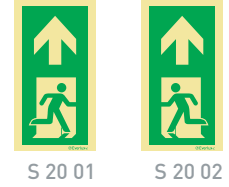

(mm)  
57x57  
83x83

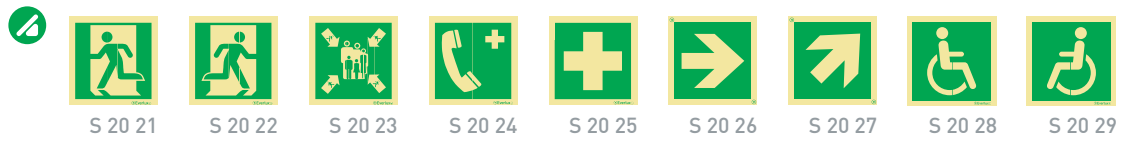

(mm)  
57x57  
83x83



(mm)  
107x57  
158x83



(mm)  
107x57  
158x83



(mm)  
57x200  
83x300



(mm)  
57x57  
83x83



## Strips for wall marking at floor level



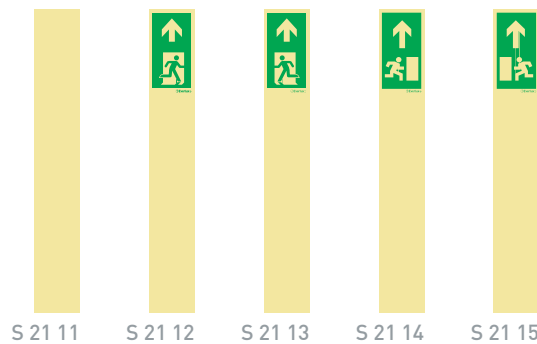

(mm)  
1000x35  
1000x57  
1000x83

Marking strips for walls and stair risers

(mm)  
800x57  
800x83

Strips to identify doorways

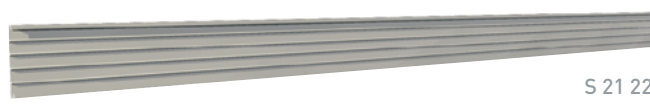
(mm)  
800x35  
800x57  
800x83  
2000x35  
2000x57  
2000x83

## Rolls for wall marking

The  Everlux<sup>®</sup> photoluminescent vinyl rolls can be used in wall mounted LLL systems and are the ideal solution for applications in irregular or rounded walls. This product can also be used for emergency equipment marking and handrail identification.

 length (m)  
10



width (mm)  
35  
57  
83

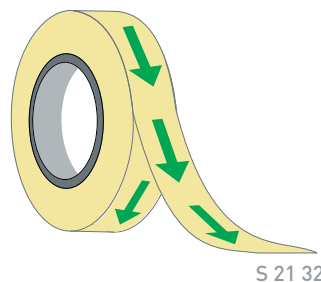
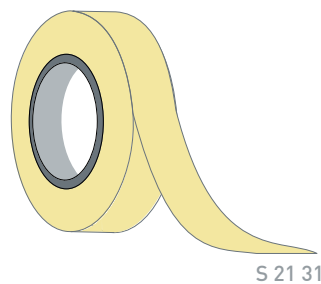







# Low Location Lighting

## System for floor and stair marking

(mm)  
1200x37  
1200x57  
1200x83

  S 21 51

  S 21 52

 S 21 53

Non-slip self-adhesive marking strips  S 21 54

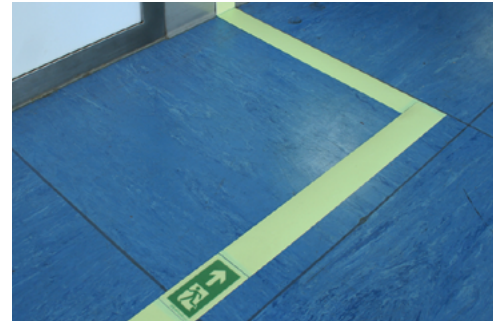



(mm)  
107x57  
158x83

Non-slip self-adhesive signs

 S 21 61

 S 21 62

 S 21 65

 S 21 66

### Ⓢ Everlux®-LLL discs

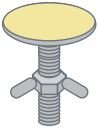
  S 21 75

 S 21 76

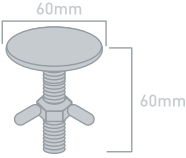
 60mm  
60mm

Discs for mesh metal floors (1 box of 12 units)



 S 21 77

 S 21 78

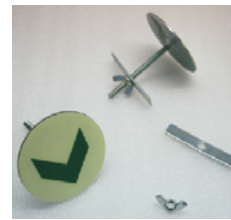
 60mm  
1.7mm



Non-slip self-adhesive discs for floors (1 sheet of 18 units)

  S 21 79

 S 21 80

 60mm  
0.4mm

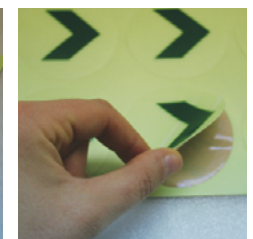

### Ⓢ Everlux®-LLL Footprint silhouettes

Photoluminescent footprint silhouettes are ideal for indicating the direction and outline of evacuation routes. Available in left and right silhouettes to be used alternately, Ⓢ Everlux®-LLL Footprint Silhouettes are made from self-adhesive, anti-slip polycarbonate which is only 0.03mm thick.

 S 21 84

 220mm  
88mm



## Non-slip self-adhesive “L” for stairs

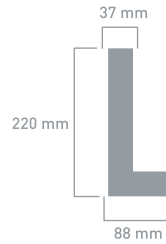

S 21 85

Designed to mark the edges of the steps. Supplied in sheets of 4 units (two signs per step)

In every flight of steps, the limits of the first and the final steps should be fully signed. You should use the strips code S 21 51

## Stairnosing - protection for steps

Aluminium framework developed for stair nosing protection. This product has anti-slip properties, even in situations where oil has been spilt, due to the grooves featured over the whole surface.

On the upper and front parts there are  Everlux<sup>®</sup>-LLL photoluminescent polycarbonate strips which also have anti-slip properties. These allow the perfect identification of the edge of the steps during a descending or ascending evacuation.

### Properties

Materials: Aluminium and  Everlux<sup>®</sup>-LLL in 0.3mm thick polycarbonate.

Sizes: Please refer to the technical drawings.

The  Everlux<sup>®</sup> protection for steps is supplied with double-sided high adherence adhesive which allows an easy application.

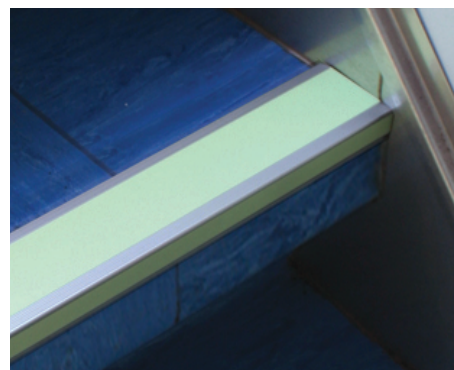
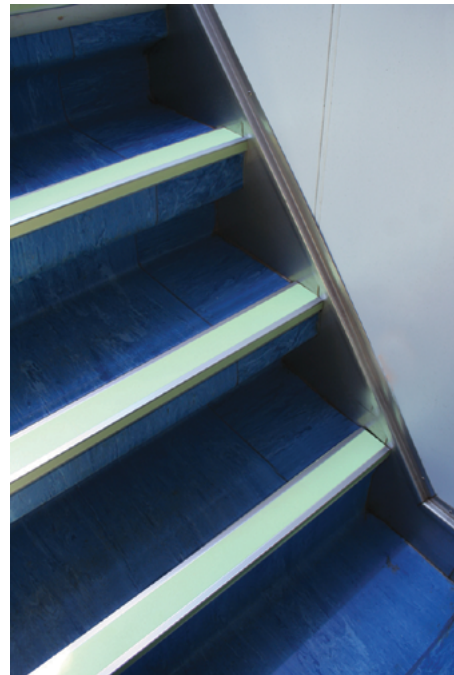
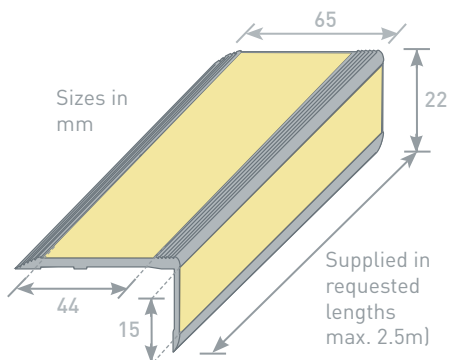

Protection for steps

S 21 90

Join the frame at two points, as in scheme 1, then rotate towards the riser until it is firmly adhered (scheme 2).

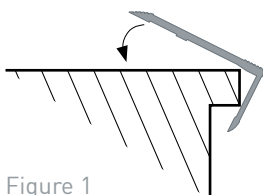

Figure 1

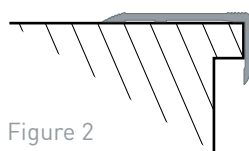

Figure 2

# Panoramic signs

## Fire equipment and evacuation

(mm)  
100x100(\*)  
150x150  
300x300

(\*) Also available  
in this size



S 25 01



S 25 02



S 25 03



(\*) S 25 11



S 25 12



S 25 13



S 25 14



S 25 15

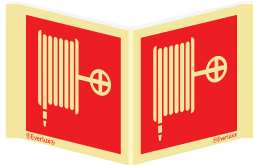

S 25 16



(\*) S 25 17



S 25 18



S 25 19

(mm)  
150x200  
200x300  
300x400



S 25 61



S 25 71



S 25 72



S 25 73



S 25 74

(mm)  
100x200  
150x300  
200x400



S 26 01

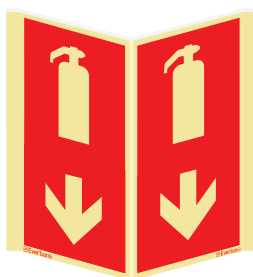

S 26 02

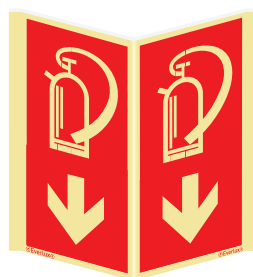

S 26 03



S 26 04

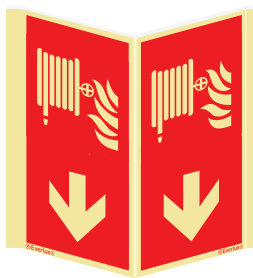

S 26 06

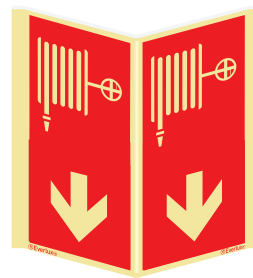

S 26 07

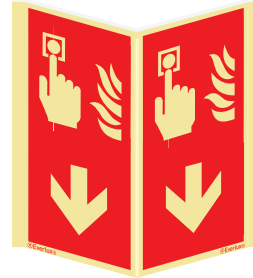

S 26 08

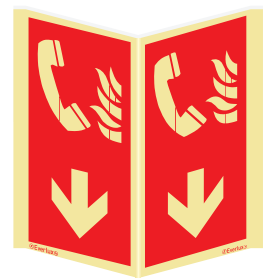

S 26 09



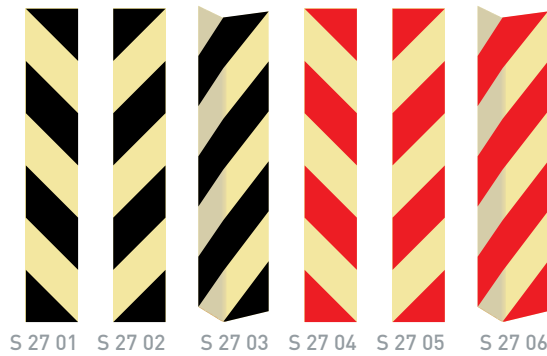
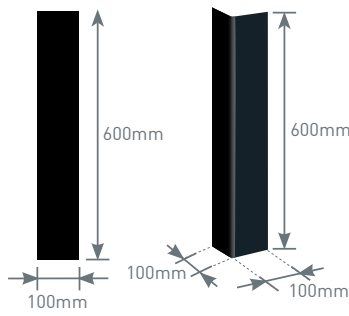

## Photoluminescent marking strips to sign dangerous areas



Recommended for areas where people circulate. Specially for the signing of machines, pillars, corners, low-level fixed or protruding objects, dangerous areas, etc

## To highlight obstacles, dangerous places and safe areas

As referenced in ISO 24409 - 1, ISO 384 - 1 specifies the following colour combinations for the layout of safety markings:

-  To indicate the location of hazards, e.g. obstacles or changes of level, or slippery surfaces.
-  To indicate prohibited areas or the location of fire fighting equipment.
-  To indicate safe areas or the location of emergency equipment.
-  To indicate mandatory instructions - e.g. "keep clear".
-  To identify the exact location of fire fighting equipment (effective alternative but not included in ISO 3864-1).



(mm)  
1000x35  
1000x57  
1000x83

Photoluminescent rigid plastic strips

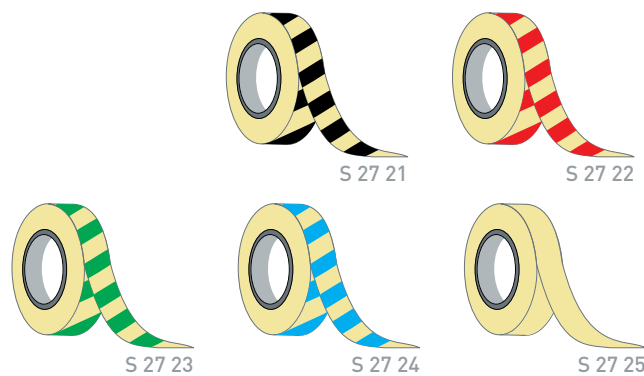
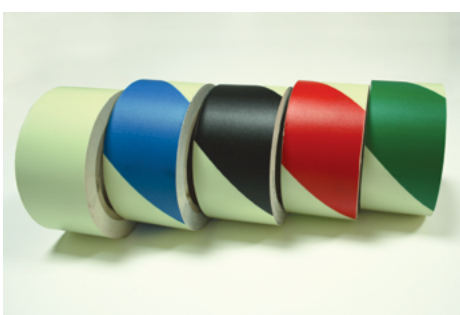

length (m)  
10  
width (mm)  
35  
57  
83

Photoluminescent self adhesive vinyl

## Self-adhesive reflective hazard warning strips to sign obstacles

Recommended for vehicle circulation areas to mark obstacles such as pillars and maximum height restrictions.

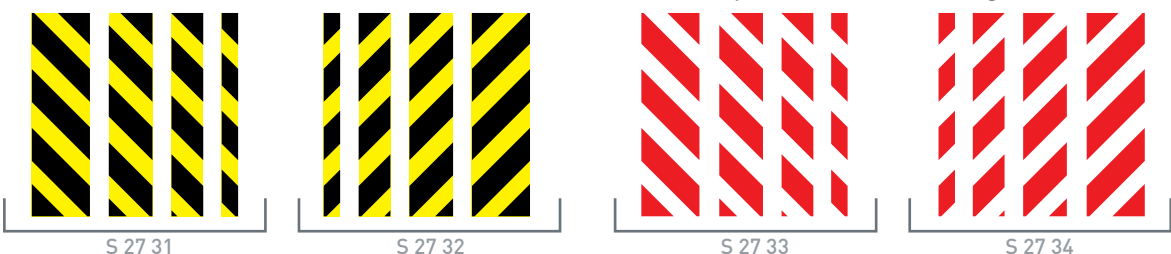

(mm)  
680x50  
680x100  
680x150  
680x200

# Warning signs

## General warning signs

(mm)

100x100

150x150

200x200

300x300(\*)

(\*) Also available

in this size



(mm)

300x100

400x150



## General warning signs



# Warning signs

## General warning signs

(mm)  
300x100  
400x150

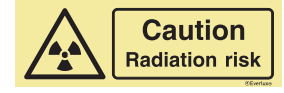
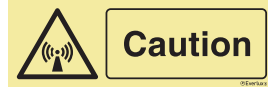
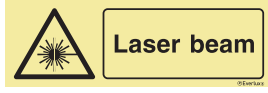

## Deck, engine room and galley warning signs

(mm)  
100x100  
150x150  
200x200



(mm)  
300x100  
400x150

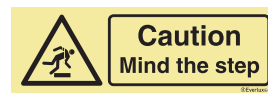
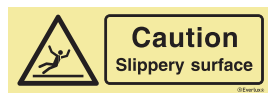
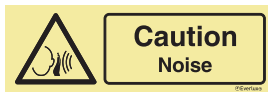
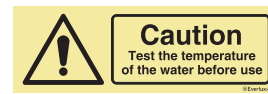
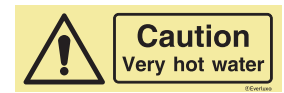

## Accommodation warning signs

(mm)  
300x100  
400x150



(mm)  
73x200



Accommodation signs are only available in white rigid plastic and white self-adhesive vinyl

## Fire and watertight door signs

					 (mm) (*)80x80 100x100 150x150 200x200 (**)300x300 (*),(**) Also available in this size
		S 34 01	S 34 02	S 34 03	
					
S 34 04	S 34 05	S 34 06	S 34 07	S 34 08	
					
S 34 09	S 34 10	S 34 11	S 34 12	S 34 13	
					
(*) S 34 14	(**) S 34 15	(**) S 34 16	(**) S 34 17	S 34 18	
					
S 34 19	(**) S 34 20	S 34 21	S 34 22	S 34 23	
					
S 34 24	S 34 25	S 34 26	S 34 27	S 34 28	
					
(**) S 34 29	S 34 30	S 34 31	S 34 32	S 34 33	
					To prevent the obstruction of escape routes, mandatory signs should be permanently fixed on all fire and watertight doors
S 34 34	S 34 35	S 34 36	S 34 37	S 34 38	

# ! Mandatory signs

## Personal protective equipment signs



(mm)  
100x100  
150x150  
200x200  
300x300[\*]

[\*] Also available  
in this size



[\*] S 35 01

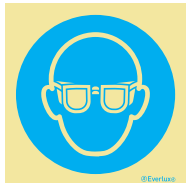

[\*] S 35 02



[\*] S 35 03

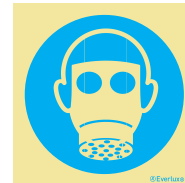

[\*] S 35 04



[\*] S 35 05



[\*] S 35 06

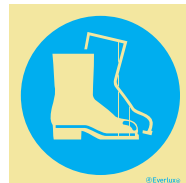

[\*] S 35 07



S 35 08



S 35 09



S 35 10

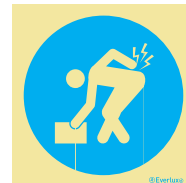

S 35 11

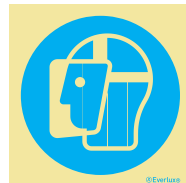

S 35 12



[\*] S 35 13

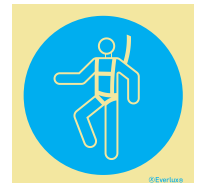

S 35 14

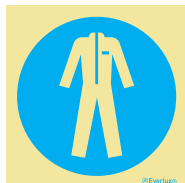

[\*] S 35 15

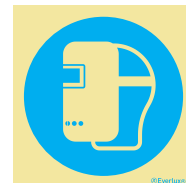

[\*] S 35 16

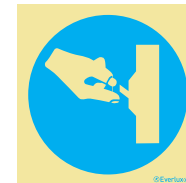

S 35 17



[\*] S 35 18



S 35 19



S 35 20

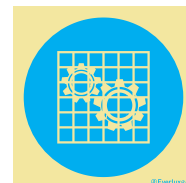

S 35 21



S 35 22

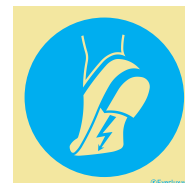



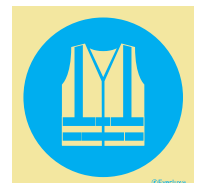



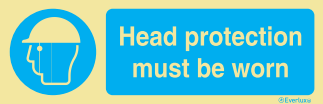

S 35 23

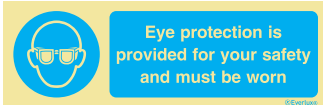
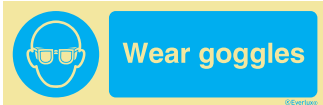
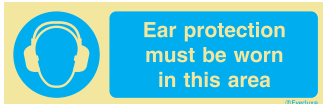

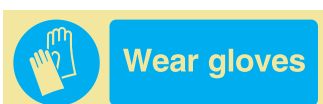
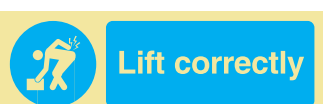
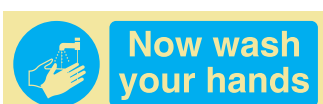
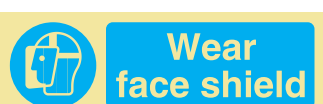
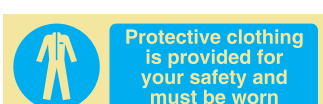
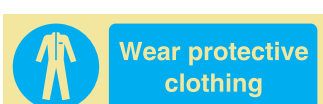
S 35 24

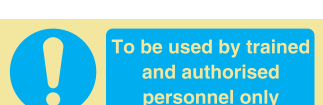
## Personal protective equipment signs

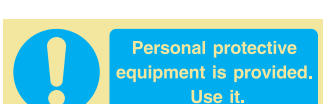
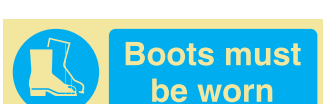
 Head protection must be worn S 35 51 [*]	 This is a safety helmet area S 35 52	 Eye protection must be worn S 35 53 [*]	 (mm) 300x100 400x150 [*]600x200 [*] Also available in this size
 Eye protection must be worn in this area S 35 54 [*]	 Eye protection is provided for your safety and must be worn S 35 60	 Wear goggles S 35 61	
 Ear protection must be worn S 35 55 [*]	 Ear protection must be worn in this area S 35 62	 Wear ear protection S 35 63	
 Respirators must be worn S 35 56	 Wear respirator S 35 64	 Masks must be worn when working here S 35 57 [*]	
 Hand protection must be worn S 35 58 [*]	 Wear gloves S 35 65	 Protective footwear must be worn S 35 59 [*]	
 Lift correctly S 35 66 [*]	 Now wash your hands S 35 71	 Use adjustable guard S 35 72	
 Wear face shield S 35 73	 Face protection must be worn when welding S 35 86	 Face protection must be worn in this area S 35 87	
 Wear safety harness S 35 74	 Protective clothing is provided for your safety and must be worn S 35 75	 Wear protective clothing S 35 76 [*]	
 High visibility clothing must be worn beyond this point S 35 77	 Wear laboratory coat S 35 78	 Wear welding mask S 35 79 [*]	
 Switch off after use S 35 80	 Keep locked S 35 81 [*]	 Sound horn S 35 82	
 To be used by trained and authorised personnel only S 35 83	 Oil spill equipment stored inside S 35 88	 Wear helmet S 35 67	To ensure the correct use of protective wear, mandatory signs must be used. Mandatory actions must be marked with mandatory signs
 Wear mask S 35 68	 Personal protective equipment is provided. Use it. S 35 69	 Boots must be worn S 35 70	

# ! Mandatory signs

## Personal protective equipment signs

(mm)  
300x100  
400x150

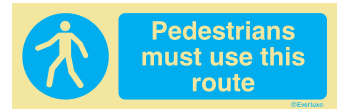
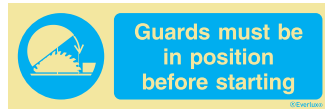
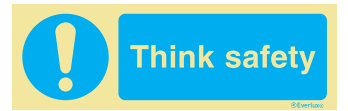
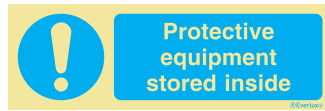

## ISPS Code mandatory signs

(mm)  
300x100  
400x150

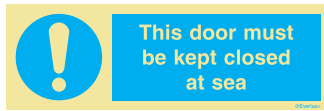
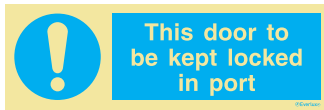





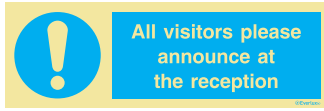
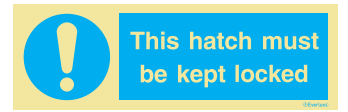
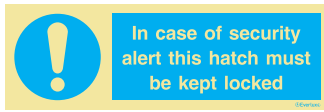
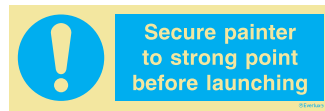
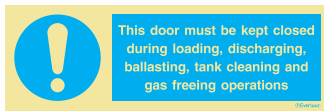
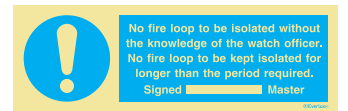
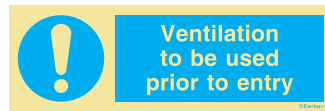
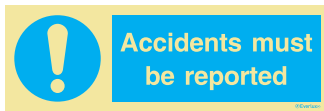
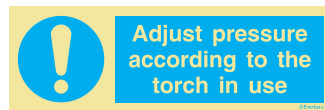
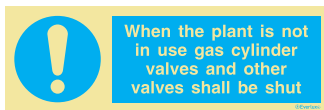















## Deck and engine room mandatory signs

(mm)  
300x100  
400x150



# Mandatory signs

## Galley mandatory signs

			(mm) 300x100 400x150 600x200
	<b>Now wash your hands</b>		
S 35 71		<b>Hand wash only</b>	
			
		<b>All handlers of food must wash their hands after visiting the toilet</b>	
			
		<b>Hair covering must be worn</b>	
S 36 46			
		<b>Utensil wash only</b>	
			
		<b>Cover all cuts and abrasions Report sickness immediately</b>	
			
		<b>Spillages must be cleaned up immediately</b>	
S 36 45			
		<b>Personal hygiene rules apply beyond this point</b>	
			
		<b>Plastic only Marine garbage disposal regulations</b>	
			
		<b>Food waste only Marine garbage disposal regulations</b>	
S 36 49			
		<b>No plastics or food waste Marine garbage disposal regulations</b>	
			
		<b>Glass only</b>	
			
		<b>Incineration only Marine garbage disposal regulations</b>	
S 36 52			
		<b>Comminution only</b>	
			
		<b>Compaction only</b>	
			
		<b>This is a food production area In the interests of hygiene protective garments must be worn</b>	
S 36 56			
		<b>Deep fat fryer</b> <small>Switch off/disconnect power supply at mains before cleaning. Avoid firing and beyond temperature set point. Ensure food is dried before commencing in oil to prevent foaming and subsequent overflowing. Always return thermostat control to zero when frying is completed. Wipe spills. 1. Ensure receptacle used is large enough to contain contents. 2. Prune control handles. 3. Clean up spillage immediately.</small>	
			
		<b>Slicing machine</b> <small>Switch off/disconnect power supply at mains before cleaning. The guard provided must be in the correct position before operating the machine. Always return the slicing thickness indicator to the zero position when work is finished to avoid injury to hand.</small>	
			
		<b>Convector oven</b> Switch off heater fan button before opening doors	
S 36 59			
		<b>Steam oven</b> Open door sufficiently to break the seal and allow steam and water to escape before opening fully	
			
		<b>Mincing / Mixing machine</b> <small>Switch off/disconnect power supply at mains before cleaning. Use only the plungers provided to push food into the mincing machine - spoons, forks, knives or sticks should be avoided. Keep hands clean when machine is in operation.</small>	
			
		<b>Potato chipping machine</b> Switch off/disconnect power supply at mains before changing or attempting to dislodge blockages	
S 36 62			
		<b>Dishwashing machine</b> <small>Switch off/disconnect power supply at mains before cleaning. Avoid overloading machine. If machine jams or stops, immediately switch off power and water supply and examine cause of stoppage. Allow machine to cool before reaching in otherwise serious scalds could occur.</small>	
			
		<b>Waste disposal machine</b> <small>Switch off/disconnect power supply at mains before cleaning. Ensure cutlery, bones, string, etc. are not mixed with food waste. Switch off power supply if machine jams or stops. Follow manufacturers inspection instructions.</small>	
			S 36 64

## Accommodation signs

			(mm) 300x100 400x150 600x200
	<b>Quiet please</b> People sleeping		
S 36 82			
		<b>Please close door quietly</b> People sleeping	
			S 36 81
			
		<b>Only human waste and toilet tissue to be flushed down these toilets</b> (No detergents, paper towels, etc.)	
			
		<b>To avoid injury take care in the shower during rough weather</b>	
			S 36 84

These signs are only available in white rigid plastic and white self-adhesive vinyl

# Prohibition signs

## Signs to prohibit dangerous actions



(mm)  
100x100  
150x150  
200x200  
300x300(\*)

(\*) Also available  
in this size



(\*) S 38 01



(\*) S 38 02



S 38 03



S 38 04



S 38 05



S 38 06



S 38 07



S 38 08

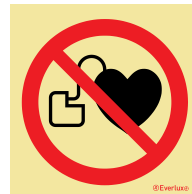

S 38 09



S 38 10



S 39 01



S 39 02



S 39 03



S 39 04



S 39 05



S 39 06



S 39 07



S 39 08



S 39 09



S 39 10



S 39 11



S 39 12



(\*) S 39 13



S 39 14



S 39 15



S 39 16

## Signs to prohibit dangerous actions

			 (mm) 300x100 400x150 (*)600x200
	(*) S 38 51	S 38 52	
			
S 38 53	S 38 54	S 38 55	
			
S 38 56	S 38 57	S 38 73	
			
S 38 74	S 38 75	(*) S 38 78	
			
(*) S 38 59	S 38 60	S 38 61	
			
S 38 62	S 38 63	S 38 64	
			
S 38 65	S 38 66	S 38 67	
			
S 38 68	S 38 69	S 38 70	
			
S 38 71	S 38 72	S 38 76	Prohibiting dangerous behaviour limits potential risks

# Prohibition signs

## Signs to prohibit dangerous actions

(mm)  
300x100  
400x150



S 39 51



S 39 52



S 39 53

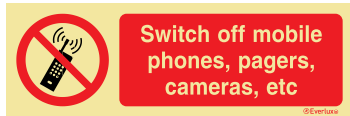

S 39 54

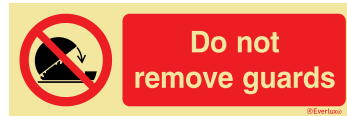

S 39 55

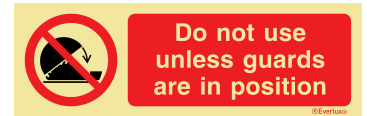

S 39 56



S 39 57



S 39 58



S 39 59



S 39 60



S 39 61



S 39 62



S 39 63



S 39 64



S 39 65



S 39 66

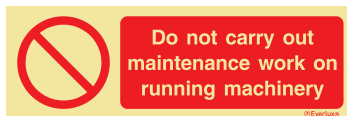

S 39 67



S 39 68

Prohibiting dangerous behaviour limits potential risks



S 39 69

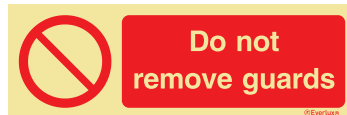

S 39 70

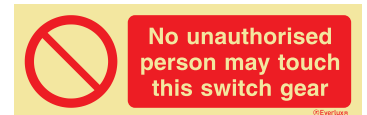

S 39 71

## ISPS Code prohibition signs

(mm)  
300x100  
400x150



S 39 81

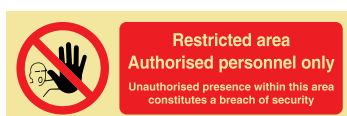

S 39 82



S 39 72



S 39 73



S 39 74



S 39 75



S 39 76

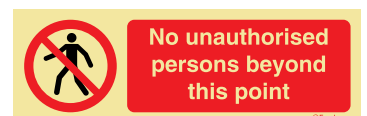

S 39 77



S 39 78









S 39 83



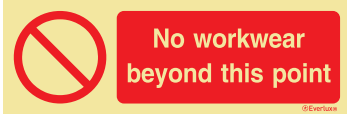



S 39 79

# Prohibition signs

## Deck and engine room prohibition signs

			 (mm) 300x100 400x150
	S 39 91	S 39 65	
			
S 38 57	S 38 65	S 39 95	

## Galley prohibition signs

			 (mm) 300x100 400x150
		S 40 01	
			
S 40 02	S 40 03	S 40 04	

## Accommodation prohibition signs

			 (mm) 300x100 400x150 [*]600x200
		[*] S 40 11	
			[*] Also available in this size
S 40 12	S 40 13	S 40 14	
			
S 40 15	S 40 17	S 40 16	
			These signs are only available in white rigid plastic and white self-adhesive vinyl
S 40 18	S 40 19	S 40 20	

# Multipurpose combination signs

## Multiple signage for danger, prohibition and obligation

(mm)  
300x200



**Danger**  
Explosion risk

In the event of fire remove bottles to safe area

S 40 51

**Danger**  
Explosion risk

Important  
Close all oxy/acetylene valves after each use

S 40 52

**Warning**  
Gas under pressure

In case of fire remove cylinders to a safe place

S 40 53

**Danger**  
Vehicle fumes

Ventilation to be in use at all times during cargo operations

S 40 54

**Caution**  
Non-ionizing radiation

Secure radar, satcom and radio equipment before accessing the monkey Island

S 40 55

**Danger**  
Keep out

S 40 56

**Danger**  
Steep ladders

Descend backwards use both handrails

S 40 57

**Danger**  
Gas

No fire  
No open lights  
No smoking

S 40 58

**Danger**  
Petroleum spirit highly flammable

No smoking  
No naked lights

S 40 59

**Warning**  
The crude oil washing lines on this vessel may contain crude oil

No valves to be opened or work to be performed without the permission of the Chief Officer

S 40 60

**Danger**  
Confined space

Do not enter without a permit to work

S 40 61

**Danger**  
Asbestos

Do not disturb

S 40 62

**Danger**  
Hazardous area

Do not enter

S 40 63

Do not throw garbage overboard

Use bins provided

S 40 64

No smoking  
No naked lights

S 40 65

(mm)  
300x400



**Warning**  
Dangerous cargo

No visitors

No smoking  
No naked lights

No mobile phones, pagers, or other electronic equipment to be turned on except in specified areas

International shore connection is located at:

S 40 71

**Security Notice**

Permit to board required. Visitors must report to the Security Officer on arrival and departure. Baggage and personal searches may be conducted.

No weapons, incendiary devices and explosives

No mobile phones, pagers, or other electronic equipment to be turned on except in specified areas

No photography

S 40 72

(mm)  
300x300



**Security notice**

Authorised access only

No unauthorised weapons or photography

Legal action will be taken on any violations

S 40 73

**Ship's security**

In accordance with the ISPS Code all persons wishing to board this vessel must prove their identities upon request and should be prepared to be frisked

No unauthorised cameras, cellular phones or weapons

Any disagree to either of these procedures will result in refusal of entry

S 40 74

**Ship's security**

All visitors please announce at the reception

No cameras

No cellular phones

S 40 75

**Ship's security**

In accordance with the ISPS Code all persons wishing to board this vessel must prove their identities be prepared to be frisked for drugs and weapons.

Any disagree to either of these procedures will result in refusal of entry.

S 40 76

# Multipurpose combination signs

## Multiple signage for danger, prohibition and obligation

**Danger**  
Explosion risk

**No smoking**

**No naked lights**

No hot work  
No chipping  
No unapproved electrical equipment

(mm)  
300x300

S 40 81

**Refrigerated Space**

**Caution**  
Low temperature and slip hazard

**No smoking**

**Wear hairnet at all times**

(mm)  
300x300

S 41 01

**Battery Locker**

**Danger**  
Battery acid

No entry to unauthorised personnel  
No smoking or naked lights

Minimum safety requirements:  
Overalls  
Face shield  
Safety gloves

S 41 02

**Galley**

**No smoking**

Wash hands before preparing food

Minimum safety requirements:  
Helmet  
Safety footwear

S 41 03

**Machinery Space**

**Caution**  
Space protected by gas flood system  
if alarm sounds vacate immediately  
Machinery may start and stop without warning

No entry to unauthorised personnel  
No smoking or naked lights except in designated areas

Minimum safety requirements:  
Overalls  
Head protection  
Ear defenders  
Safety boots

S 41 04

**Gas Bottle Store**

**Danger**  
Compressed gases

No entry to unauthorised personnel  
No smoking or naked lights

**Keep well ventilated**

S 41 05

**Paint Store**

**Danger**  
Flammable liquid

No entry to unauthorised personnel  
No smoking or naked lights

**Keep well ventilated**

S 41 06

**Chemical Locker**

**Danger**  
Flammable liquid

No entry to unauthorised personnel  
No smoking or naked lights

**Keep well ventilated**

S 41 07

**Switch Gear**

**Danger**  
High voltage

No entry to unauthorised personnel  
No smoking or naked lights

Minimum safety requirements:  
Overalls  
Safety gloves  
Ear defenders  
Safety boots

S 41 08

**Forecastle Space**

**Caution**  
Space protected by gas flood system  
if alarm sounds vacate immediately  
Machinery may start and stop without warning

No entry to unauthorised personnel  
No smoking or naked lights

Minimum safety requirements:  
Overalls  
Head protection  
Ear defenders  
Safety boots

S 41 09

**Fridge Machinery**

**Danger**  
Toxic fumes  
Machinery may start without warning

No entry to unauthorised personnel  
No smoking or naked lights

**Keep well ventilated**

S 41 10

**Emergency Generator**

**Danger**  
High voltage  
Machinery may start without warning

No entry to unauthorised personnel  
No smoking or naked lights

Minimum safety requirements:  
Overalls  
Safety gloves  
Ear defenders  
Safety boots

S 41 11

**Steering Gear**

**Danger**  
Moving machinery

No entry to unauthorised personnel  
No smoking or naked lights

Minimum safety requirements:  
Overalls  
Head protection  
Ear defenders  
Safety boots

S 41 12

**Pump Room**

**Caution**  
Confined space with moving machinery

No entry to unauthorised personnel  
No smoking or naked lights

Minimum safety requirements:  
Overalls  
Head protection  
Ear defenders  
Safety boots

S 41 13

# i Information signs

## Safety signs according to the ICAO and IMO Document 9636

(mm)  
150x150  
200x200  
300x300  
400x400



The ICAO and IMO joint publication Document 9636 specifies the signs to provide guidance information to persons at airports and marine terminals.  
The "First Aid", "No Smoking", "No Entry/No trespassing" and "Carry no weapons on board" signs should be designed according to the colours specified in Section II of this publication whilst the colours of general information signs can be decided by national or local authorities keeping in mind that readability is of the foremost importance.



S 42 01



S 42 02



S 42 03



S 42 04

(mm)  
150x150  
200x200  
300x300  
400x400



S 42 51



S 42 52

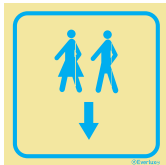

S 42 53

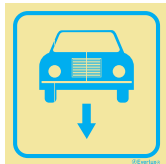

S 42 54

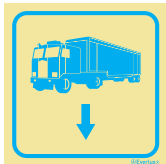

S 42 55



S 42 56



S 42 57



S 42 58



S 42 59



S 42 60



S 42 61



S 42 62



S 42 63



S 42 64



S 42 65



S 42 66



S 42 67



S 42 68



S 42 69

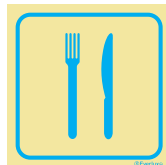

S 42 70



S 42 71



S 42 72



S 42 73



S 42 74



S 42 75



S 42 76



S 42 77

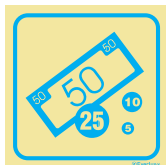

S 42 78



S 42 79



S 42 80

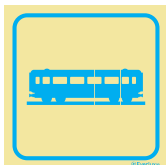

S 42 81



S 42 82



S 42 83



S 42 84



S 42 85



S 42 86



S 42 87



S 42 88



S 42 89

## Security Level signs

The  Everlux® Security Level signs are available in a photoluminescent magnetic finish. This is the ideal solution to secure adhesion to all suitable metallic surfaces. The magnetic finish also allows for the quick and easy change of security level indicator. The selling unit of this product is comprised of 4 components.

 (mm)  
200x180



S 42 10



S 42 11



S 42 12



S 42 13

 (mm)  
200x100

## Crew only access

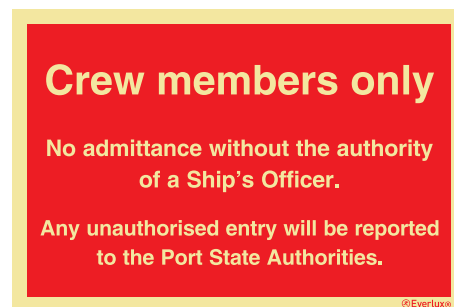

S 42 20

 (mm)  
300x200

## Ultra-destructible seals



[\*] S 42 25

 (mm)  
[\*] 150x30  
 (\*\*) 300x30



[\*\*] S 42 26

[\*] [\*\*] Only available in this size



[\*] S 42 27

Only available in non-photoluminescent ultra-destructible self-adhesive vinyl. Detailed technical sheet available on request.

# ISPS Code signs

## ISPS compliant notices

(mm)  
900x450





**THIS SHIP COMPLIES WITH THE**  
**I.M.O. ISPS CODE**

**STRICT SECURITY MEASURES & PROCEDURES ARE ENFORCED**  
**NO OFFENSIVE WEAPONS ALLOWED**

**VISITORS WILL BE MET ON DECK AND MUST REGISTER ONBOARD WITH**  
**A PHOTOGRAPHIC IDENTIFICATION DOCUMENT AND MAY BE SUBJECT**  
**TO PERSONAL OR BAGGAGE SEARCHES**

**YOUR CO-OPERATION IS EXPECTED IN COMPLIANCE WITH MARITIME**  
**SECURITY REQUIREMENTS**

**THE MASTER**

S 42 30

(mm)  
300x200



**RESTRICTED AREA**

**AUTHORIZED**

**PERSONNEL ONLY**

UNAUTHORIZED PRESENCE WITHIN THIS AREA  
CONSTITUTES A BREACH OF SECURITY

©Everlux

S 42 31

## CCTV signs

(mm)  
150x150[\*]  
200x300[\*\*]



[\*] [\*\*] Only  
available in this size



**This vessel  
is under**

**CCTV**

**Surveillance**

[\*\*] S 42 40



**CCTV**

**In operation**

[\*] S 42 41



**VDR**

**Voice recording is  
fitted on this bridge**

[\*] S 42 42

(mm)  
300x100





24 h

**This area is  
under CCTV  
surveillance**

©Everlux

S 42 43



excellence by Evertex safety signs for super yachts



excellence by Evertex is a safety signage solution that creates an harmonious co-existence between the sign elements and the upscale environment, emphasising on the aesthetics and decorative style of the vessels. The structure of every excellence by Evertex sign is comprised of top quality and innovative materials. This sign range is distinct from other safety signs as the use of coloured pigments allows both the pictogram and the background colours to be visible in the dark. excellence by Evertex is a patented product.



(mm)  
60x60

		<p>S 43 21</p>	<p>S 43 22</p>	<p>S 43 23</p>	<p>S 43 24</p>	<p>S 43 25</p>	
<p>S 43 26</p>	<p>S 43 27</p>	<p>S 43 28</p>	<p>S 43 01</p>	<p>S 43 29</p>	<p>S 43 02</p>	<p>S 43 30</p>	<p>S 43 03</p>
<p>S 43 04</p>	<p>S 43 05</p>	<p>S 43 06</p>	<p>S 43 07</p>	<p>S 43 31</p>	<p>S 43 32</p>	<p>S 43 08</p>	<p>S 43 09</p>
<p>S 43 34</p>	<p>S 43 10</p>	<p>S 43 11</p>	<p>S 43 12</p>	<p>S 43 13</p>	<p>S 43 35</p>	<p>S 43 36</p>	<p>S 43 37</p>
<p>S 43 38</p>	<p>S 43 39</p>	<p>S 43 14</p>	<p>S 43 15</p>	<p>S 43 16</p>	<p>S 43 17</p>	<p>S 43 18</p>	<p>S 43 19</p>
<p>S 43 20</p>	<p>S 43 80</p>	<p>S 43 81</p>	<p>S 43 82</p>	<p>S 43 83</p>	<p>S 43 84</p>	<p>S 43 85</p>	<p>S 43 86</p>
<p>S 43 87</p>	<p>S 43 88</p>	<p>S 43 89</p>	<p>S 43 90</p>	<p>S 43 92</p>	<p>S 43 93</p>	<p>S 43 94</p>	<p>S 43 95</p>

# Safety signs for super yachts

## Life-saving appliances, fire, mandatory and prohibition signs

(mm)  
50x50

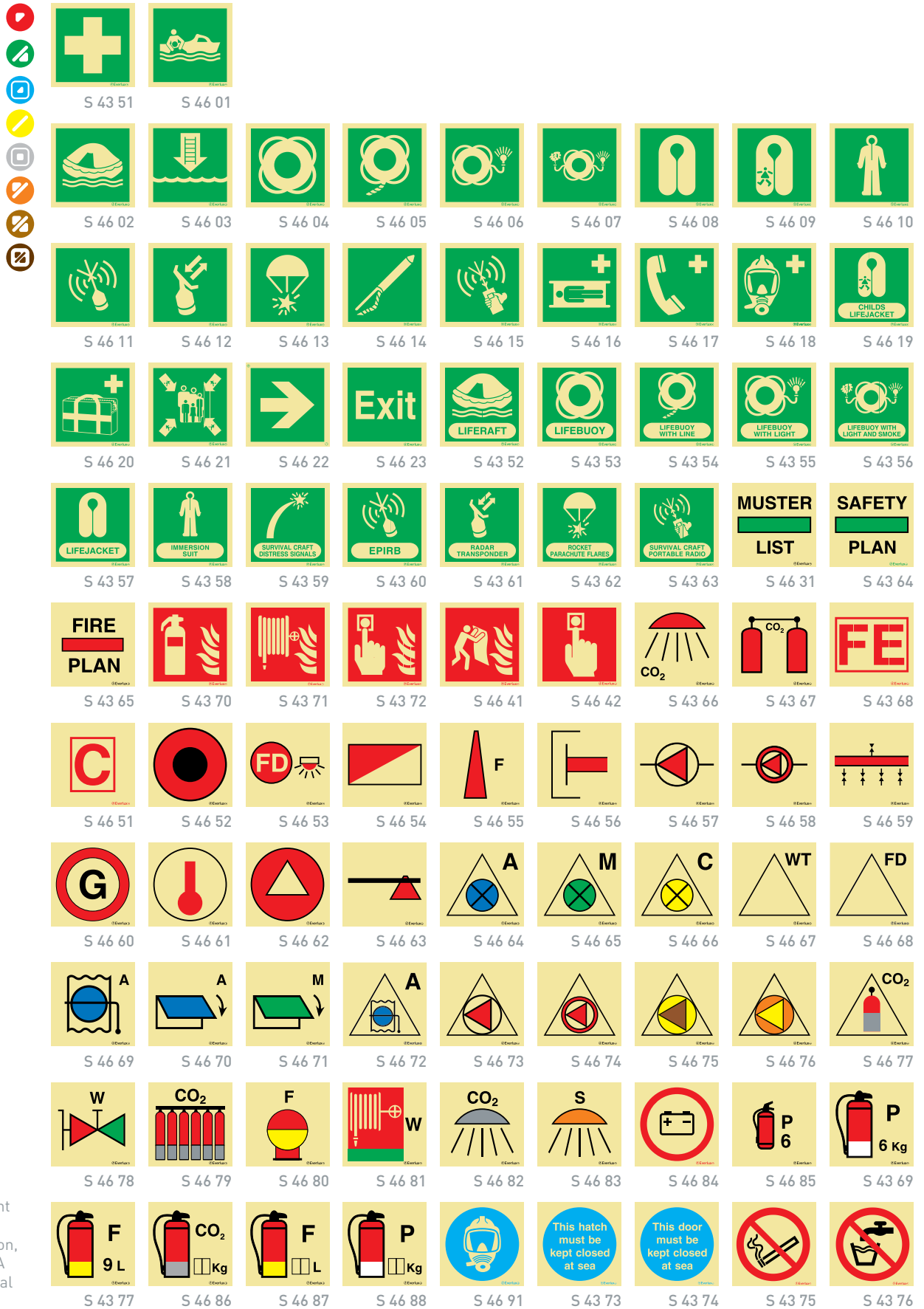

Photoluminescent safety signs, in smaller dimension, according to MCA Large Commercial Yacht Code (LY3).

(mm)  
150x50





The Offshore Wind Industry has significantly expanded in the recent past. This is a unique industry with specific structures and vessels where service technicians and crews face equally unique hazards. The Everlux photoluminescent safety signs for the Offshore Wind Industry are the ideal solution to identify them.

## Warning signs



S 44 01



S 44 02



S 44 03



S 44 04

(mm)  
Diam. 80

Self-adhesive signs  
supplied in sheets of  
12 units

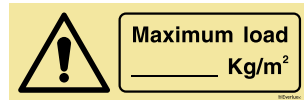

S 44 11

(mm)  
300x100



S 44 12



S 44 13



S 44 14



S 44 15

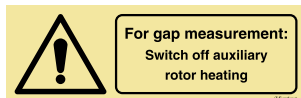

S 44 16



S 44 17

Only available in  
self-adhesive vinyl

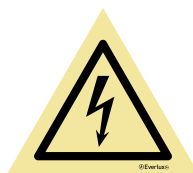

S 44 32



S 44 33

(mm)  
base 150  
base 200

Only available in  
self-adhesive vinyl



S 44 36

(mm)  
200x300  
300x400

Only available in  
rigid plastic and  
aluminium

# Offshore wind - safety signs

## Prohibition signs

(mm)  
Diam. 80

Self-adhesive sign  
supplied in sheets  
of 12 units

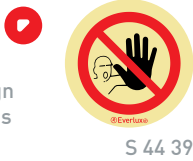

(mm)  
300x100

Only available in  
self-adhesive vinyl



(mm)  
200x200

Magnetic sign

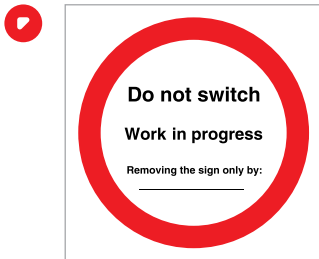

## Mandatory and personal protective equipments signs

(mm)  
Diam. 80

Self-adhesive signs  
supplied in sheets of  
12 units



(mm)  
300x100

Only available in  
self-adhesive vinyl



## Signs for manually operated devices

(mm)  
150x150  
200x150(\*)

(\*) Only available  
in this size

Only available in  
self-adhesive vinyl

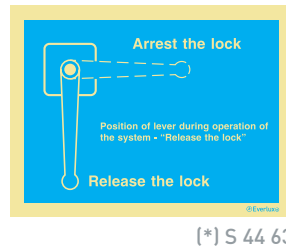
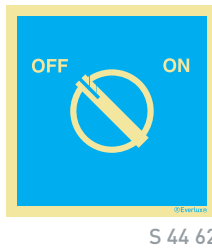
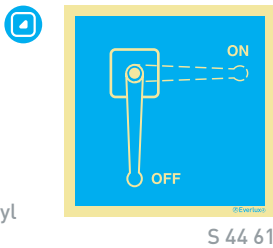

## Emergency, fire and prohibition signs

(mm)  
150x150  
200x200  
300x300  
400x400  
600x600



Only available in  
self-adhesive vinyl

## Safety procedures

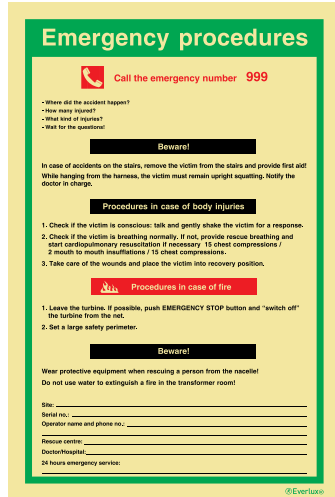

S 44 70

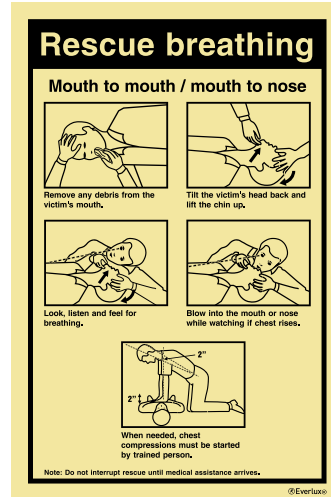

S 44 77

(mm)  
200x300



Only available in self-adhesive vinyl

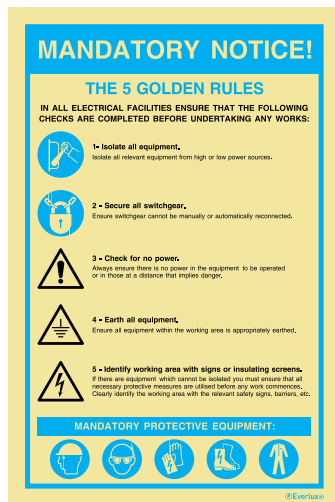

(\*) S 44 76

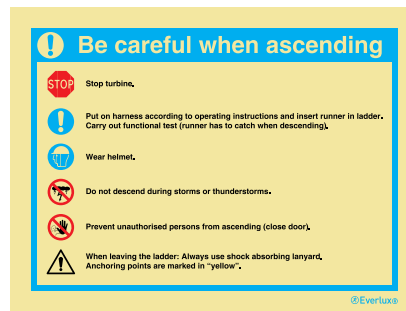

S 44 77

(mm)  
200x150  
(\*) 200x300

(\*) Only available in this size

Only available in self-adhesive vinyl

## Offshore wind - safety signs bilingual cross reference table

Supplementary texts in the following languages:			
EN	NO - EN	NL - EN	ES - EN
S4411	S4418	S4425	S4405
S4412	S4419	S4426	S4406
S4413	S4420	S4427	S4407
S4414	S4421	S4428	S4482
S4415	S4422	S4429	S4483
S4416	S4423	S4430	S4484
S4417	S4424	S4431	S4485
S4433	S4434	S4435	S4486
S4436	S4437	S4438	S4487
S4440	S4443	S4446	S4488
S4441	S4444	S4447	S4489
S4442	S4445	S4448	S4490
S4449	S4450	S4451	S4491
S4458	S4459	S4460	S4492
S4461	S4464	S4467	S4493
S4462	S4465	S4468	S4494
S4463	S4466	S4469	S4495
S4470	S4471	S4472	S4496
S4473	S4474	S4475	S4497
S4476	S4478	S4480	S4498
S4477	S4479	S4481	S4499

The ©Everlux® safety signs for the Offshore Wind Industry are available in several bilingual supplementary text options: NO - EN, NL - EN and ES - EN. If you wish to order these signs in any of the bilingual options please refer to the item code cross reference table and use the respective sign code in your purchase order.

## Safety signs for water parks, swimming pools and beaches



Safety signage in water parks is very important due to the increase in the number of these infra-structures as well as the related number of serious accidents occurring in these areas. Safety signs should be used in water activity areas in order to alert its users to the rules in place and to any potential hazards, thereby consequently prevent dangerous behaviour. These signs are in compliance with ISO 20712-1 and BS 5499-11.

Our water safety signs are manufactured in 3mm thick white aluminium composite material and feature an anti-graffiti protective clear film. This film also provides signs with effective protection for outdoor installations, humid environments or in the presence of water containing a strong acid or alkaline content (eg: lime and chlorine).

### Prohibition signs

(mm)

200x200

300x300

400x400(\*)

(\*) Also available  
in this size



(\*) S 45 01



(\*) S 45 02



(\*) S 45 03



(\*) S 45 04



S 45 05



(\*) S 45 06



(\*) S 45 07



(\*) S 45 08



(\*) S 45 09



(\*) S 45 10



S 45 11



(\*) S 45 12



(\*) S 45 13



S 45 14



S 45 15



(\*) S 45 16



(\*) S 45 17



S 45 18



S 45 19



S 45 20









S 45 21





## Warning signs

							(mm) (* )200x200 300x300
			S 45 51	S 45 52	S 45 53		(*) Also available in this size
							
S 45 54	S 45 55	S 45 56	S 45 57	S 45 58	S 45 59		
							
S 45 60	S 45 61	S 45 62	S 45 63	(* ) S 45 64	S 45 65		
							
S 45 66	S 45 67	S 45 68	S 45 69	S 45 70	S 45 71		

## Mandatory signs

				(mm) 200x200 300x300
	S 45 81	S 45 82		
				
	S 45 83	S 45 84		

## Information signs

					(mm) 200x200 300x300 (* )400x400
S 45 91	(* ) S 45 92	S 45 93	S 45 94		(*) Also available in this size

# Temporary tie tags



## Warning sign tags

(mm)  
75x150



All the EverLux® tie tags have a clear protective film which provides them with a rewritable feature

## Prohibition sign tags

(mm)  
75x150



## Mandatory sign tags

(mm)  
75x150



## Anti-splashing tape



Anti-Splashing Tape Model N° 888FN was designed to protect pipeline installations against leakage and splashing of fuel oil, lube oil and other flammable oils. This tape is used for applications in the marine and offshore industries in screening of pipe joints, valves and fittings in accordance with SOLAS Consolidated Edition, 2004, Chapter II-2/ Regulations 4, item 2.2.5.3.

The Anti-Splashing Tape Model N° 888FN is available in tape format of various sizes versions and an adhesive agent is applied on one side and covered by separator film to ensure easy installation.

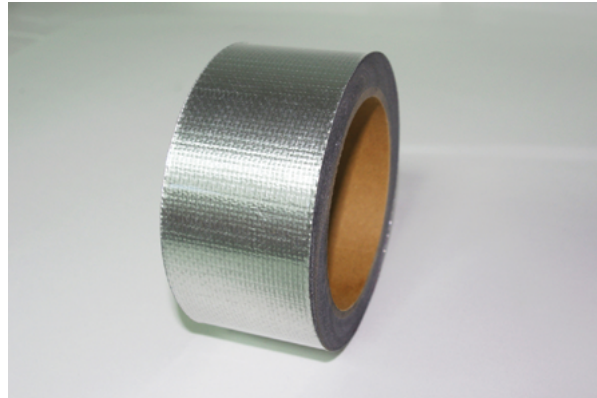

Tape components:

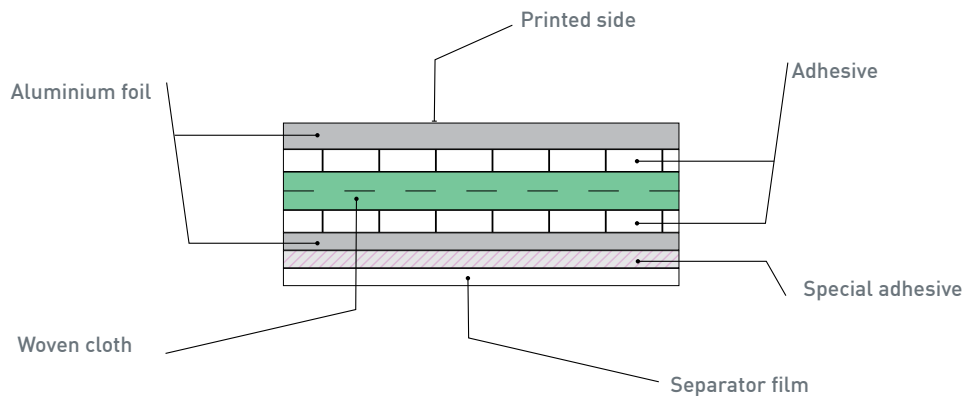

Aluminium foils are superimposed on both sides of the glass woven cloth together with a special acrylic adhesive agent to form a laminate structure.

The tape has the ship classification societies' logos printed on its surface to ensure the market of its full compliance with SOLAS regulations.

Specification of tape <sup>1</sup>	
For use:	On pipes and joints for heavy fuel oil
Maximum temperature:	424° K (150 °C)
Maximum pressure:	3.0 MPa (30 bar)
Approved pressure:	1.5 MPa (15 bar)

Availability	
Reference:	Size (Width x Length) /Roll
S 51 00	25mm x 10m
S 51 01	35mm x 10m
S 51 02	50mm x 10m
S 51 03	100mm x 10m
S 51 04	140mm x 10m
S 51 05	250mm x 10m
S 51 06	500mm x 10m

<sup>1</sup> Reference - Details of approval by Lloyd's Register(LR)

# Pipe content identification



Pipe identification colour-coded tape according to ISO 14726:2008 and NORSOK L-004



length (m)  
25

width (mm)  
50



The  Everlux<sup>®</sup> marking solution for piping systems is available in single colour and in multiple colour self-adhesive vinyl rolls.  
The single colour (main colours which indicate a group of similar media) rolls can be combined in order to attain the colour coding that identifies specific contents.  
The multiple colour rolls are available with the different colour combinations for every specific pipe content and are the ideal solution to save installation time.  
The  Everlux<sup>®</sup> marking solutions for pipe content identification are compliant with ISO 14726: 2008 and NORSOK L-004.

Medium	Colour	Item code
Waste media	Black	S 50 01
Fresh water	Blue	S 50 02
Fuel	Brown	S 50 03
Sea water	Green	S 50 04
Non-flammable gases	Grey	S 50 05
Air and sounding pipes	Maroon	S 50 06
Oils other than fuels	Orange	S 50 07
Steam	Silver	S 50 08
Fire fighting	Red	S 50 09
Acids, alkalis	Violet	S 50 10
Air in ventilation systems	White	S 50 11
Flammable gases	Yellow	S 50 12
Flow arrows	-	S 50 00

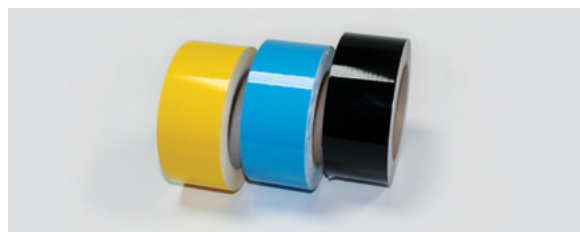

These self-adhesive vinyl rolls can be combined (additional colour) in order to attain the colour coding that identifies each specific content.

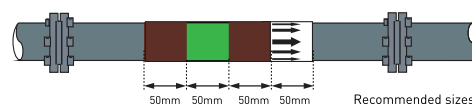

**Installation Points:** Pipelines should be marked at least once in each room; at each penetration point in bulkheads, walls and decks; close to each valve; within a distance of 3m to 5m of the length of the pipeline whereby local conditions may require more marking due to pipe bends or the close proximity of pipes for different services.

Waste Media	Colours	Item codes
Black water		S 50 01 - S 50 02 - S 50 01
Waste oil/used oil		S 50 01 - S 50 03 - S 50 01
Bilge water		S 50 01 - S 50 04 - S 50 01
Exhaust gas		S 50 01 - S 50 05 - S 50 01
Grey water		S 50 01 - S 50 11 - S 50 01
Sewage, contaminated		S 50 01 - S 50 12 - S 50 01

Fresh Water	Colours	Item codes
Fresh water, sanitary		S 50 02 - S 50 03 - S 50 02
Potable water		S 50 02 - S 50 04 - S 50 02
Distillate		S 50 02 - S 50 05 - S 50 02
Gas-turbine wash water		S 50 02 - S 50 07 - S 50 02
Feed water		S 50 02 - S 50 08 - S 50 02
Cooling fresh water		S 50 02 - S 50 10 - S 50 02
Chilled water		S 50 02 - S 50 11 - S 50 02
Condensate		S 50 02 - S 50 12 - S 50 02

Fuel	Colours	Item codes
Heavy fuel oil (HFO)		S 50 03 - S 50 01 - S 50 03
Aviation fuel		S 50 03 - S 50 02 - S 50 03
Biological fuel		S 50 03 - S 50 10 - S 50 03
Gas-turbine fuel		S 50 03 - S 50 11 - S 50 03
Marine diesel oil (MDO)		S 50 03 - S 50 12 - S 50 03

Flow arrows	Colours	Item codes
Flow arrows		S 50 00

Sea water	Colours	Item codes
Decontamination water		S 50 04 - S 50 02 - S 50 04
Sea water, sanitary		S 50 04 - S 50 03 - S 50 04
Ballast water		S 50 04 - S 50 10 - S 50 04
Cooling sea water		S 50 04 - S 50 12 - S 50 04

Non-flammable gases	Colours	Item codes
Oxygen		S 50 05 - S 50 02 - S 50 05
Inert gas		S 50 05 - S 50 03 - S 50 05
Nitrogen		S 50 05 - S 50 04 - S 50 05
Refrigerant		S 50 05 - S 50 06 - S 50 05
Compressed air LP (Low pressure)		S 50 05 - S 50 07 - S 50 05
Compressed air HP (High pressure)		S 50 05 - S 50 09 - S 50 05
Control air/regulating air		S 50 05 - S 50 10 - S 50 05
Breathing air*		S 50 05 - S 50 11 - S 50 05
Breathing gas*		S 50 05 - S 50 12 - S 50 05

\* This marking is used in submarines for distribution systems of breathing air from cylinders.

Fire fighting/ fire protection	Colours	Item codes
Fire-fighting water		S 50 09 - S 50 04 - S 50 09
Fire-fighting gas		S 50 09 - S 50 05 - S 50 09
Sprinkler water		S 50 09 - S 50 07 - S 50 09
Spray water		S 50 09 - S 50 10 - S 50 09
Fire-fighting powder		S 50 09 - S 50 11 - S 50 09
Fire-fighting foam		S 50 09 - S 50 12 - S 50 09

# Pipe content identification

## Pipe identification colour-coded tape according to ISO 14726: 2008 and NORSOK L-004



Steam	Colours	Item codes
Steam for heating purposes		S 50 08 - S 50 01 - S 50 08
Driving steam		S 50 08 - S 50 04 - S 50 08
Exhaust steam		S 50 08 - S 50 11 - S 50 08
Supply steam		S 50 08 - S 50 12 - S 50 08

Flammable gases	Colours	Item codes
Hydrogen		S 50 12 - S 50 02 - S 50 12
Acetylene		S 50 12 - S 50 05 - S 50 12
Liquid gas		S 50 12 - S 50 10 - S 50 12

Non-flammable gases	Colours	Item codes
Oxygen		S 50 05 - S 50 02 - S 50 05
Inert gas		S 50 05 - S 50 03 - S 50 05
Nitrogen		S 50 05 - S 50 04 - S 50 05
Refrigerant		S 50 05 - S 50 06 - S 50 05
Compressed air HP (High pressure)		S 50 05 - S 50 09 - S 50 05
Control air/regulating air		S 50 05 - S 50 10 - S 50 05
Breathing air*		S 50 05 - S 50 11 - S 50 05
Breathing gas*		S 50 05 - S 50 12 - S 50 05

\* This marking is used in submarines for distribution systems of breathing air from cylinders.

Air and sounding pipes	Colours	Item codes
Waste media		S 50 06 - S 50 01 - S 50 06
Fresh water		S 50 06 - S 50 02 - S 50 06
Fuel		S 50 06 - S 50 03 - S 50 06
Sea water		S 50 06 - S 50 04 - S 50 06
Non-flammable gases		S 50 06 - S 50 05 - S 50 06
Oils other than fuels		S 50 06 - S 50 07 - S 50 06
Steam		S 50 06 - S 50 08 - S 50 06
Fire fighting		S 50 06 - S 50 09 - S 50 06
Acids, alkalis		S 50 06 - S 50 10 - S 50 06
Ventilation system		S 50 06 - S 50 11 - S 50 06
Flammable gases		S 50 06 - S 50 12 - S 50 06

Oils other than fuels	Colours	Item codes
Thermal fluid		S 50 07 - S 50 02 - S 50 07
Lubrication oil for gas turbines		S 50 07 - S 50 04 - S 50 07
Hydraulic fluid		S 50 07 - S 50 05 - S 50 07
Lubrication oil for steam turbines		S 50 07 - S 50 08 - S 50 07
Lubrication oil for gears		S 50 07 - S 50 10 - S 50 07
Lubrication oil for internal combustion engines		S 50 07 - S 50 12 - S 50 07

Non-flammable gases	Colours	Item codes
Oxygen		S 50 05 - S 50 02 - S 50 05
Inert gas		S 50 05 - S 50 03 - S 50 05
Nitrogen		S 50 05 - S 50 04 - S 50 05
Refrigerant		S 50 05 - S 50 06 - S 50 05
Compressed air LP (Low pressure)		S 50 05 - S 50 07 - S 50 05
Compressed air HP (High pressure)		S 50 05 - S 50 09 - S 50 05
Control air/regulating air		S 50 05 - S 50 10 - S 50 05
Breathing air*		S 50 05 - S 50 11 - S 50 05
Breathing gas*		S 50 05 - S 50 12 - S 50 05

\* This marking is used in submarines for distribution systems of breathing air from cylinders.

Air in ventilation systems	Colours	Item codes
Discharge air		S 50 11 - S 50 01 - S 50 11
Mechanical supply air, cold		S 50 11 - S 50 02 - S 50 11
Natural exhaust air		S 50 11 - S 50 03 - S 50 11
Atmospheric air		S 50 11 - S 50 04 - S 50 11
Mechanical exhaust air		S 50 11 - S 50 05 - S 50 11
Decontaminated supply air		S 50 11 - S 50 06 - S 50 11
Mechanical recirculated air		S 50 11 - S 50 07 - S 50 11
Mechanical supply air, warm		S 50 11 - S 50 08 - S 50 11
Smoke clearance		S 50 11 - S 50 09 - S 50 11
Conditioned supply air		S 50 11 - S 50 10 - S 50 11
Natural supply air		S 50 11 - S 50 12 - S 50 11

length (m)  
25

width (mm)  
50

## Multiple colour rolls according to ISO 14726: 2008 and NORSOK L-004

length (m)  
25

width (mm)  
100

S 52 01 Black Water

S 52 02 Waste oil/ used oil

S 52 03 Bilge water

S 52 04 Exhaust gas

S 52 05 Grey water

S 52 06 Sewage, contaminated

S 52 07 Decontamination water

S 52 08 Sea water, sanitary

S 52 09 Ballast water

S 52 10 Cooling sea water

S 52 11 Fresh Water

S 52 12 Fresh water, sanitary

S 52 13 Potable water

S 52 14 Distillate

S 52 15 Gas-turbine wash water

S 52 16 Feed water

S 52 17 Cooling fresh water

# Pipe content identification

Multiple colour rolls according to ISO 14726: 2008 and NORSOK L-004

length (m)  
25

width (mm)  
100







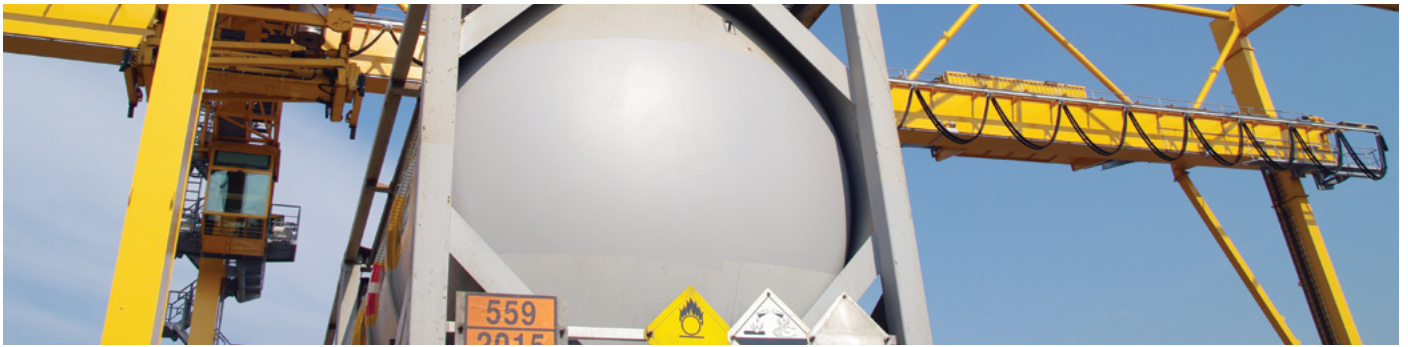







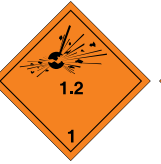
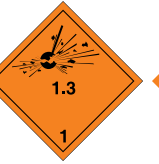













S 52 18 Chilled water	S 52 19 Condensate	S 52 20 Non-flammable gases	S 52 21 Oxygen	S 52 22 Inert gas	S 52 23 Nitrogen
S 52 24 Refrigerant	S 52 25 Compressed air LP (low pressure)	S 52 26 Compressed air HP (high pressure)	S 52 27 Control air/ regulating air	S 52 28 Breathing air	S 52 29 Breathing gas
S 52 30 Steam for heating processes	S 52 31 Driving steam	S 52 32 Exhaust steam	S 52 33 Supply steam	S 52 34 Waste media	S 52 35 Fresh water
S 52 36 Fuel	S 52 37 Sea water	S 52 38 Non-flammable gases	S 52 39 Oils other than fuels	S 52 40 Steam	S 52 41 Fire fighting
S 52 42 Acids, Alkalis	S 52 43 Ventilation system	S 52 44 Flammable gases	S 52 45 Oils other than fuels	S 52 46 Thermal fluid	S 52 47 Lubrication oil for gas turbines
S 52 48 Hydraulic fluid	S 52 49 Lubrication oil for steam turbines	S 52 50 Lubrication oil for gears	S 52 51 Lubrication oil for internal combustion engines	S 52 52 Heavy fuel oil (HFO)	S 52 53 Aviation fuel
S 52 54 Biological fuel	S 52 55 Gas-turbine fuel	S 52 56 Marine diesel oil (MDO)	S 52 57 Fire fighting water	S 52 58 Fire-fighting gas	S 52 59 Sprinkler water
S 52 60 Spray water	S 52 61 Fire-fighting powder	S 52 62 Fire-fighting foam	S 52 63 Discharge air	S 52 64 Mechanical supply air, cold	S 52 65 Natural exhaust air
S 52 66 Atmospheric air	S 52 67 Mechanical exhaust air	S 52 68 Decontaminated supply air	S 52 69 Mechanical recirculated air	S 52 70 Mechanical supply air, warm	S 52 71 Smoke clearance
S 52 72 Conditioned supply air	S 52 73 Natural supply air	S 52 74 Flammable gases	S 52 75 Hydrogen	S 52 76 Acetylene	S 52 77 Liquid gas

## Signs according to the IMDG Code specifications





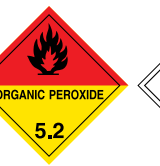

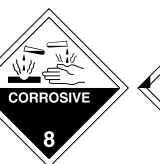
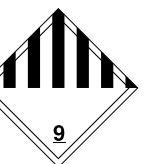



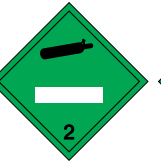
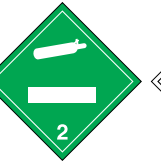

The International Maritime Dangerous Goods (IMDG) Code has been developed to create a uniform international code for the transport of dangerous goods by sea. The IMDG Code became mandatory in January 2004 through the adoption of the amendments to SOLAS chapter VII (Carriage of Dangerous Goods).

## Hazard warning signs with classification numbers

						    	(mm)
S 55 01	S 55 02	S 55 03	S 55 04	S 55 05	S 55 06		100x100
							200x200
S 55 07	S 55 08	S 55 09	S 55 10	S 55 11	S 55 12		250x250
						300x300	
S 55 14	S 55 15	S 55 16	S 55 17	S 55 18	S 55 19	400x400	
							
S 55 21	S 55 22	S 55 23	S 55 24	S 55 25	S 55 26		
							
S 55 28	S 55 29	S 55 30	S 55 31	S 55 32	S 55 33		
							
S 55 34							

## Hazard warning signs with UN numbers

						    	(mm)
S 56 01	S 56 02	S 56 03	S 56 04	S 56 05	S 56 06		100x100
							
S 56 07							

# Signs according to the IMDG Code

## Hazard warning signs with UN numbers

(mm)  
100x100  
200x200  
250x250  
300x300  
400x400

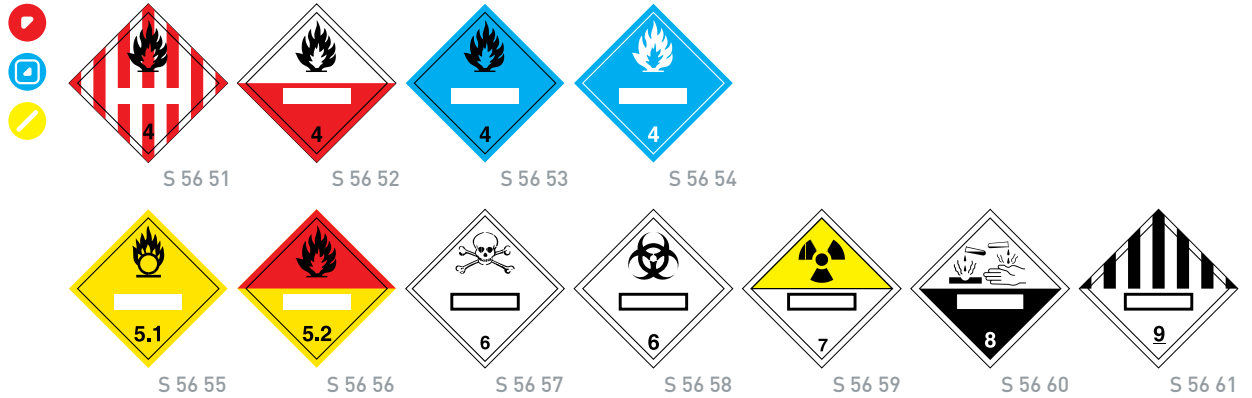

## Marking signs for packages

(mm)  
100x150  
150x200

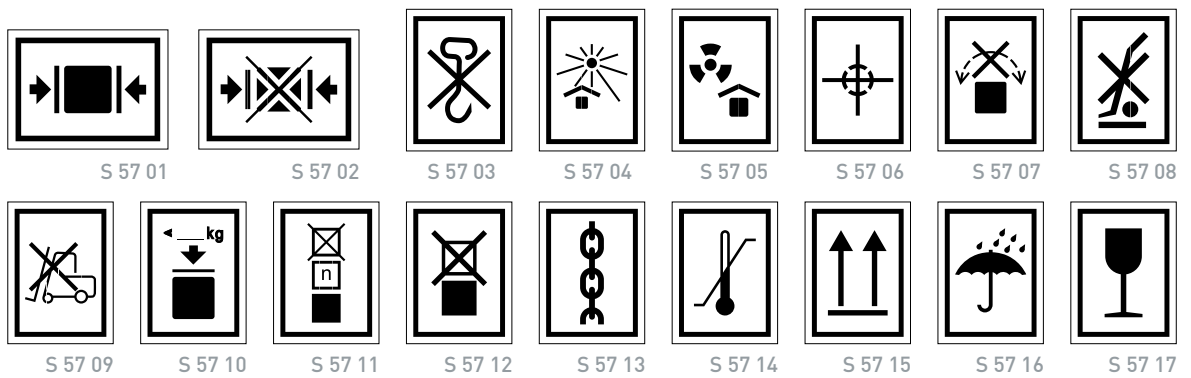

(mm)  
100x100  
250x250  
300x300  
base 300(\*)

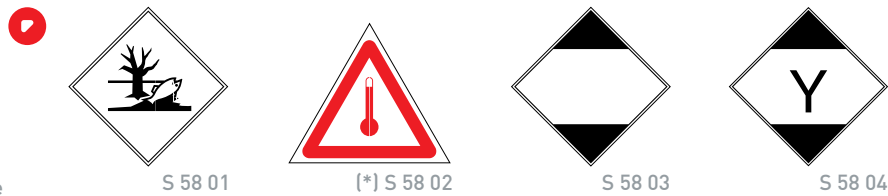

(\*) Only available in this size

(mm)  
100x100  
250x250  
300x250(\*)

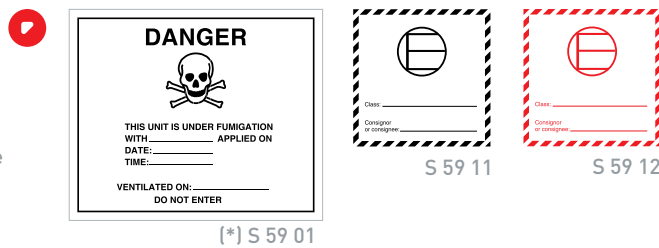

(\*) Only available in this size

## Safety signage according to Regulation (EC) No 1272/2008 on classification, labelling and packaging of substances and mixtures

(mm)  
100x100  
150x150  
200x200  
300x300



## Info panels with sign symbols and meaning descriptions



The IMO International Safety Management (ISM) Code was developed with the aim of implementing safety practises at sea which would lead to the prevention of human injury or loss of life as well as the prevention of damage to the environment and property.

The  Everlux® safety procedures are in compliance with the ISM Code and provide you with the necessary training and information requirements that must be displayed on board.



S 60 01



S 60 02

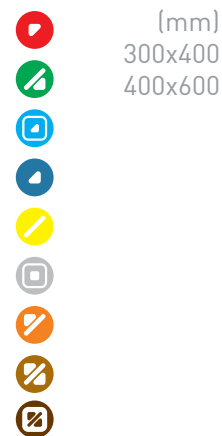

(mm)  
300x400  
400x600





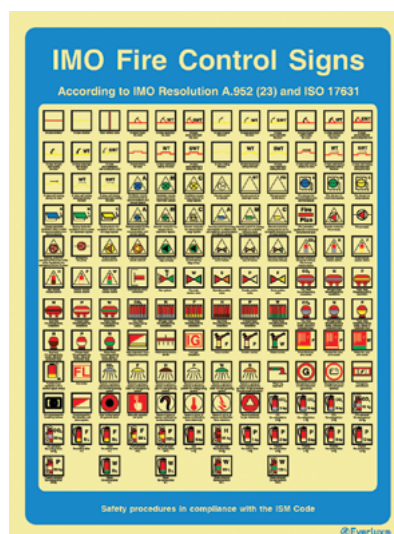

S 60 03



S 60 04



## Evacuation and life-saving safety procedures

-  (mm)
-  300x400
-  400x600
- 
- 

### Liferaft Launching

Inflatable liferaft launching procedures



**1 Automatic Release**  
 1. Release handle  
 2. Release handle  
 3. Release handle  
 4. Release handle

**2 Manual Release**  
 1. Release handle  
 2. Release handle  
 3. Release handle  
 4. Release handle

**3 Launch Liferaft**  
 1. Release handle  
 2. Release handle  
 3. Release handle  
 4. Release handle

**4 Inflate Liferaft**  
 1. Release handle  
 2. Release handle  
 3. Release handle  
 4. Release handle

Safety procedures in compliance with the ISM Code

S 60 53

### Davit Launched Liferafts

Instructions for davit launching inflatable liferafts



**1 Prepare the launch area**  
 1. Release handle  
 2. Release handle  
 3. Release handle  
 4. Release handle

**2 Prepare liferaft**  
 1. Release handle  
 2. Release handle  
 3. Release handle  
 4. Release handle

**3 Lift raft and turn out deck to present position**  
 1. Release handle  
 2. Release handle  
 3. Release handle  
 4. Release handle

**4 Release liferaft**  
 1. Release handle  
 2. Release handle  
 3. Release handle  
 4. Release handle

Safety procedures in compliance with the ISM Code

S 60 54

### Davit Launched Liferaft Procedures

Preparing for launching



**1 After mooring services all done according to ship**

**2 Short descent procedure**

**3 Lower to waterline**

**4 Operate hook release (in above water)**

**5 Clear away from vessel**

**6 Tilt up the hook for the raft descent**

Safety procedures in compliance with the ISM Code

S 60 73

### Inflatable Liferafts

Essential procedures after launching



**1 Righting upturned raft**

**2 Board quickly**

**3 Move clear of the ship**

**4 Release the sea anchor**

**5 Close the entrance**

**6 Further procedures**

Safety procedures in compliance with the ISM Code

S 60 55

### Lifeboat Launching

Launching open/semi-enclosed lifeboats safety procedures. Make sure that painter line is fitted.

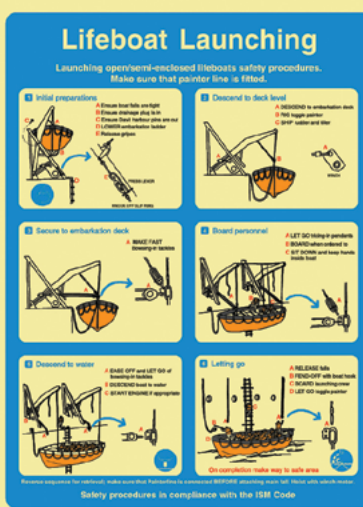

**1 Initial preparations**

**2 Descend to deck level**

**3 Secure to embarkation deck**

**4 Board personnel**

**5 Descend to water**

**6 Letting go**

Safety procedures in compliance with the ISM Code

S 60 56

### Hoisting Hook Directions For Launching Procedures

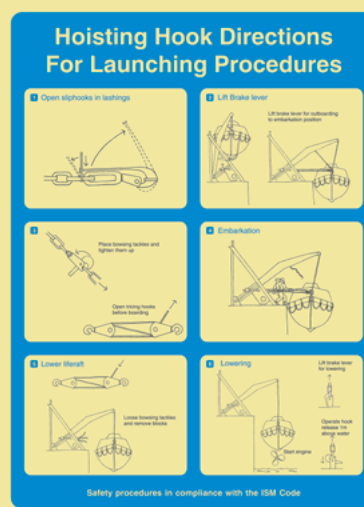

**1 Open slings in lifelines**

**2 Lift Slake lever**

**3 Embarkation**

**4 Lower liferaft**

**5 Lowering**

Safety procedures in compliance with the ISM Code

S 60 72



## Evacuation and life-saving safety procedures

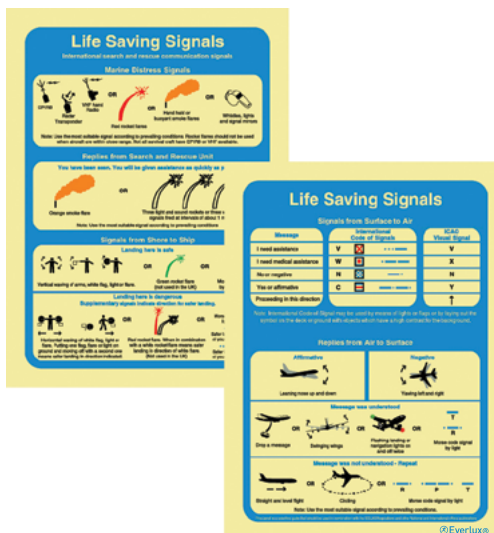

(mm)  
150x200  
200x300

Item S 60 71 is a double sided panel

S 60 71



S 61 01

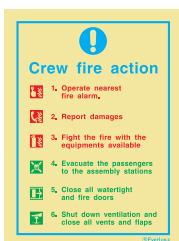

S 61 02



S 61 03

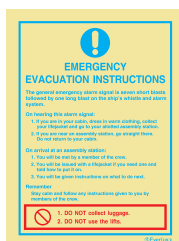

S 61 04



S 61 05

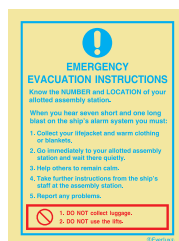

S 61 06



(mm)  
150x200  
200x300



S 61 07



S 61 08

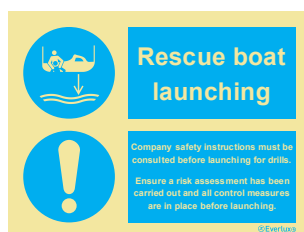

S 61 09



(mm)  
200x150



S 61 21

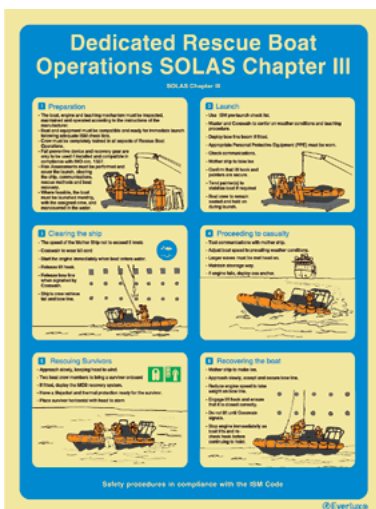

S 61 27



S 61 22



(mm)  
300x400  
400x600









## Health and safety operational procedures

### Hot Works

Recommended safety preparations for hot works

Hot work consists of any operation which generates sufficient heat to ignite flammable materials.

- Plan the work**
  - Consider the risks involved in the working conditions when planning the work. The location, work, equipment, personnel to be involved and weather. Put the practice permit to work and establish safety entry procedures.
  - Plan emergency escape routes and establish communication and emergency signals.
- Minimise the risks**
  - Consider what lower flammable limit exceeding the hot work work and heat transfer to adjoining pipes and areas.
  - Make sure operators wear proper protective clothing and equipment.
  - Place safety signs and protect other workers from sparks, fumes and electricity.
- Prepare work area**
  - Clear work area of all debris.
  - Wet down and back off all nearby services.
  - Pipes and valves should be drained of liquids and gas first.
  - Flare piping and check safe areas before operation.
  - Flammable areas must have continuous ventilation and protection of lights. Area must also be certified as safe for an unattended permit.
- Safety during and after work**
  - A fire watch person with suitable equipment and clear view of work area must be assigned. Check for fire in all work preparation and finish.
  - Welding and cutting equipment must be inspected. All welders must be notified and gas bottles must be safety placed and secured.

**SAFETY: STOPPING WORK, MAKE SURE YOU ARE NOT WITH NEARBY. ALWAYS CHECK FOR SPARKS AND FUMES TO BE REMOVED OR CONTROLLED.**

Safety procedures in compliance with the ISM Code

S 63 03

### Welding & Flamecutting

Safety procedures during welding operations

- General**
  - Welding is a highly skilled and potentially dangerous process.
  - Operators must be trained, qualified and competent in the use of the equipment, to ensure safety measures and to be fully notified of equipment.
  - Significant risks to health and safety are associated with welding and flamecutting.
  - Sufficient ventilation must be provided and maintained throughout the work.
  - Welding and flamecutting must be carried out in a safe and secure environment.
- Protective clothing**
  - When welding, operators must wear flame-resistant protective clothing.
  - Welding gloves, eye protection, ear protection, and other approved safety equipment must be worn.
  - Welding gloves must be replaced when they become worn.
  - Welding gloves must be replaced when they become worn.
  - Welding gloves must be replaced when they become worn.
- Precautions against fire & explosions**
  - Welding and flamecutting operations must be carried out in a safe and secure environment.
  - Welding and flamecutting operations must be carried out in a safe and secure environment.
  - Welding and flamecutting operations must be carried out in a safe and secure environment.
- Electric welding equipment**
  - Welding equipment must be inspected and maintained.
  - Welding equipment must be inspected and maintained.
  - Welding equipment must be inspected and maintained.
- Precautions during arc welding**
  - Welding equipment must be inspected and maintained.
  - Welding equipment must be inspected and maintained.
  - Welding equipment must be inspected and maintained.
- Precautions during gas welding & cutting**
  - Welding equipment must be inspected and maintained.
  - Welding equipment must be inspected and maintained.
  - Welding equipment must be inspected and maintained.

Safety procedures in compliance with the ISM Code

S 63 04

### Personal Protective Equipment

Choosing the correct personal safety equipment

- Head protection**
  - Welding helmets, safety glasses, safety goggles, and face shields must be worn.
  - Welding helmets must be worn.
  - Welding helmets must be worn.
- Respiratory protection**
  - Welding masks, respirators, and other respiratory protection equipment must be worn.
  - Welding masks must be worn.
  - Welding masks must be worn.
- Eye protection**
  - Welding helmets, safety glasses, safety goggles, and face shields must be worn.
  - Welding helmets must be worn.
  - Welding helmets must be worn.
- Ear protection**
  - Welding helmets, safety glasses, safety goggles, and face shields must be worn.
  - Welding helmets must be worn.
  - Welding helmets must be worn.
- Hand protection**
  - Welding gloves, safety glasses, safety goggles, and face shields must be worn.
  - Welding gloves must be worn.
  - Welding gloves must be worn.
- Foot protection**
  - Welding helmets, safety glasses, safety goggles, and face shields must be worn.
  - Welding helmets must be worn.
  - Welding helmets must be worn.
- Specialized Equipment**
  - Welding helmets, safety glasses, safety goggles, and face shields must be worn.
  - Welding helmets must be worn.
  - Welding helmets must be worn.

Safety procedures in compliance with the ISM Code

S 63 05

### Self Contained Breathing Apparatus

Safety measures of use in hazardous conditions

Where recharging facilities are not available, empty and low charged cylinders should be labelled and stored separately. Confirm that all cylinders are valid. Read and learn the manufacturer's instructions.

- Check weekly and before using**
  - Check on face mask, air lines, filters, gauges and hoses, all straps.
  - Check on all cylinders on the site and in spare cylinders.
  - Check on all cylinders on the site and in spare cylinders.
- Donning the breathing apparatus**
  - Put the air on to clean an environment.
  - Place the air on through the air lines.
  - Place the air on through the air lines.
- Regulating and verifying the functions**
  - Place face mask, with air line.
  - Tighten straps, before to use.
  - Check on all cylinders on the site and in spare cylinders.
- Getting ready to enter compartment**
  - Check on all cylinders on the site and in spare cylinders.
  - Check on all cylinders on the site and in spare cylinders.
- Initial operation**
  - Check on all cylinders on the site and in spare cylinders.
  - Check on all cylinders on the site and in spare cylinders.
- After operational use**
  - Check on all cylinders on the site and in spare cylinders.
  - Check on all cylinders on the site and in spare cylinders.

Safety procedures in compliance with the ISM Code

S 63 06

### Enclosed Space Entry

Safety procedures for entering enclosed spaces

- Enclosed spaces are dangerous**
  - Due to HAZARDOUS, only TRAINED and COMPETENT PERSONNEL should be allowed to enter enclosed spaces.
- Prepare space for entry**
  - Clear the space and free to breathe as much as air as possible.
  - Ventilate thoroughly and continuously before and during entry. Purge with 15% O<sub>2</sub> if necessary.
  - TEST ATMOSPHERE before and during entry at various levels and locations. Oxygen to be 20.9%, low and flammable gas concentrations as per company regulations.
- Prepare equipment**
  - TOOLS are to be inspected at entrance and used for job. No tools back when completing the task.
  - ILLUMINATION must be adequate and certified for hazardous areas.
  - ACCESS must be adequate. Ladders and safety rails must be in good condition.
- Communications and procedures**
  - COMPETENT PERSONS are always responsible for all operations.
  - CHECK LIST and entry permit must be completed and signed by the Master or a Senior Officer.
  - SAFETY PERSONS must not be removed. Otherwise, another entry permit must be issued.
- Prepare safety equipment**
  - COMMUNICATIONS must be tested and in good order before person at entrance and before entry. Rescue procedures to be planned and practised.
  - SAFETY EQUIPMENT must be worn. Head, face, body, gloves, boots and personal gas monitors must be in good condition.
  - RESCUE EQUIPMENT must be at entrance and ready for use. Rescue procedures to be planned and practised.
- Avoid additional hazards**
  - Regular safety checks are vital while space is open or occupied.
  - ALLEGED SPACES may be a hazard and not to be used. Regular safety checks are vital while space is open or occupied.
  - NO HOT WORKS. The above procedure is not applicable for hot work. Company regulations must be strictly followed at all times whenever work is to be done in any space for hot work.

Safety procedures in compliance with the ISM Code

S 63 07

### Enclosed Space and Tank Rescue

Safety procedures for recovering a casualty from a dangerous atmosphere

- Raise the alarm**
  - Call for assistance and give details of the incident.
  - Do not attempt to perform a rescue without the appropriate equipment or the full emergency team.
  - Rescue of a casualty from a tank. (Use rescue team. Update emergency team.)
- Commence rescue**
  - Rescue team must use rescue and communication equipment, protective clothing, breathing apparatus, personal gas monitors. Check if all equipment functions correctly. First aid rescue must be used with communication equipment.
  - Do not attempt to perform a rescue without the appropriate equipment or the full emergency team.
  - Rescue of a casualty from a tank. (Use rescue team. Update emergency team.)
- Emergency first aid and rescue**
  - Rescue the victim and stop rescue breathing.
  - Rescue team must use rescue and communication equipment, protective clothing, breathing apparatus, personal gas monitors. Check if all equipment functions correctly. First aid rescue must be used with communication equipment.
- First aid and after care**
  - Carry out first aid to the casualty.
  - Rescue team must use rescue and communication equipment, protective clothing, breathing apparatus, personal gas monitors. Check if all equipment functions correctly. First aid rescue must be used with communication equipment.

Safety procedures in compliance with the ISM Code

S 63 08

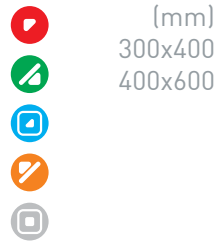

(mm)  
300x400  
400x600

# Safety awareness and training procedures

## Health and safety operational procedures

(mm)  
300x400  
400x600



### Safety Signs for Enclosed Space Entry

Safety signs used to mark hazardous areas

**Test the atmosphere of any space before entering. Some enclosed spaces on this vessel may contain a hazardous atmosphere that will not support life.**

**Examples:**  
Water tanks  
Coffers  
Ballast tanks  
Fuel tanks  
Cargo tanks  
Bilge spaces  
Paint stores  
Trunkways  
Dry cargo spaces  
Purdy rooms

All examples of these spaces shall be marked with the following signs: **NOT TO BE SUBMERGED**

	<b>Danger</b> Low oxygen level	Even a small decrease in the oxygen level can kill you at alarming speed without notice. Ruddy tanks and some cargoes absorb oxygen from the air.
	<b>Danger</b> Flammable atmosphere	The risk of explosion is of critical importance. Remember that even small pockets of gas displace the air you need. Suffocation and backdraft is fast with no possibility of escape.
	<b>No smoking or naked lights</b>	
	<b>Danger</b> Toxic vapours	Some cargoes in all trades may release poisonous vapour into the air. You may not see or smell it. A duration feeling followed by blackout and death is the likely conclusion.
	<b>No access</b> Authorized personnel only	One space can contain all these dangers.

Proper safety procedures for entering enclosed spaces must be carried out before allowing entrance. If in doubt check with someone in authority. **DO NOT ENCLOSE YOUR LIFE TO SAVE TIME OR CONSIDER IT DIFFICULT. FOLLOW THE ENCLOSED SPACE ENTRY SAFETY PROCEDURES.**

Safety procedures in compliance with the ISM Code

S 63 09

### Engine & Machinery Room Safety

Safe working procedures

<p><b>General</b></p> <ul style="list-style-type: none"> <li>Be safety alert, be fit to work, avoid and prohibit hazards.</li> <li>Define entering a machinery space, unless you are the following or another person with authority:             <ul style="list-style-type: none"> <li>Personnel with authority</li> <li>Personnel with authority</li> <li>Personnel with authority</li> <li>Personnel with authority</li> <li>Personnel with authority</li> </ul> </li> <li>Do not enter a machinery space unless you are authorised.</li> <li>Always wear safety harness</li> <li>Do not use any tools or equipment inside the space.</li> </ul>	<p><b>Unattended machinery spaces - UMS</b></p> <ul style="list-style-type: none"> <li>Do not enter. The officer in charge of the bridge must be alerted.</li> <li>Reporting and communication procedures must be clearly understood before leaving.</li> <li>Safety procedures must be displayed at all times.</li> <li>Always wear safety harness and use fall arrest.</li> <li>Do not use any tools or equipment inside the space.</li> <li>Do not use any tools or equipment inside the space.</li> <li>Do not use any tools or equipment inside the space.</li> </ul>
<p><b>Main engines and auxiliaries</b></p> <ul style="list-style-type: none"> <li>When starting machinery, be safety alert, wearing safety harness.</li> <li>Do not use any tools or equipment inside the space.</li> <li>Do not use any tools or equipment inside the space.</li> <li>Do not use any tools or equipment inside the space.</li> </ul>	<p><b>Bulbers</b></p> <ul style="list-style-type: none"> <li>Machinery operating procedures are to be clearly displayed and observed.</li> <li>Always wear safety harness and use fall arrest.</li> <li>Do not use any tools or equipment inside the space.</li> <li>Do not use any tools or equipment inside the space.</li> <li>Do not use any tools or equipment inside the space.</li> </ul>
<p><b>Refrigeration machine</b></p> <ul style="list-style-type: none"> <li>The space of the readily self-contained refrigerant of refrigeration machinery shall be clearly marked with the words 'REFRIGERANT'.</li> <li>Always wear safety harness and use fall arrest.</li> <li>Do not use any tools or equipment inside the space.</li> <li>Do not use any tools or equipment inside the space.</li> </ul>	<p><b>Workshops and stores</b></p> <ul style="list-style-type: none"> <li>Make use of these items as equipment and storage space.</li> <li>Always wear safety harness and use fall arrest.</li> <li>Do not use any tools or equipment inside the space.</li> <li>Do not use any tools or equipment inside the space.</li> </ul>

Safety procedures in compliance with the ISM Code

S 63 10

### Craneage Safety

Craneage hand signals and safe working practices

In the indicated direction					
Signal with one hand and the other on head			Signal with one hand and the other on head		
Signal with both hands			Signal with both hands		
<p>All signals must have a current certificate for the ISM Code.</p> <p>Operator must have had adequate training.</p> <p>Do not use any tools or equipment inside the space.</p> <p>Do not use any tools or equipment inside the space.</p> <p>Do not use any tools or equipment inside the space.</p> <p>Do not use any tools or equipment inside the space.</p>					

Safety procedures in compliance with the ISM Code

S 63 11

### Working Aloft or Outboard

Be aware of the risks when working outboard and aloft

<p><b>Preparation</b></p> <ul style="list-style-type: none"> <li>All equipment must be used in a safe and verified space.</li> <li>Make sure equipment is safe, has current test certificate, operators and necessary permits.</li> <li>Carry out the assessment.</li> <li>Do not use any tools or equipment inside the space.</li> </ul>	<p><b>Risk awareness</b></p> <ul style="list-style-type: none"> <li>Sea state</li> <li>Exhaust gases</li> <li>Fuel leaks</li> <li>Slippery surfaces</li> <li>Accidental radiation</li> <li>Overboard discharge</li> <li>Proximity</li> </ul>
<p><b>Bringing</b></p> <ul style="list-style-type: none"> <li>Clear road to bring on job and emergency action.</li> <li>Use appropriate equipment and tools.</li> <li>Use appropriate equipment and tools.</li> <li>Use appropriate equipment and tools.</li> </ul>	<p><b>Working aloft</b></p> <ul style="list-style-type: none"> <li>Use fall arrest.</li> <li>Use fall arrest.</li> <li>Use fall arrest.</li> <li>Use fall arrest.</li> </ul>
<p><b>Use of portable equipment</b></p> <ul style="list-style-type: none"> <li>No lifting or working aloft, unless done in a safe and verified space.</li> <li>Make sure equipment is safe, has current test certificate, operators and necessary permits.</li> <li>Carry out the assessment.</li> <li>Do not use any tools or equipment inside the space.</li> </ul>	<p><b>Working outboard</b></p> <ul style="list-style-type: none"> <li>No lifting or working aloft, unless done in a safe and verified space.</li> <li>Make sure equipment is safe, has current test certificate, operators and necessary permits.</li> <li>Carry out the assessment.</li> <li>Do not use any tools or equipment inside the space.</li> </ul>

Safety procedures in compliance with the ISM Code

S 63 12

### Bunkering

Safety procedures

<p><b>Procedures before bunkering</b></p> <ul style="list-style-type: none"> <li>Establish communication between ship and shore.</li> <li>Prepare for lighting equipment.</li> <li>Check the type and amount of fuel.</li> <li>Check the amount of fuel to be bunkered.</li> <li>Check the amount of fuel to be bunkered.</li> </ul>	<p><b>Check</b></p> <ul style="list-style-type: none"> <li>Ensure that the correct fuel is used.</li> <li>Ensure that the correct fuel is used.</li> <li>Ensure that the correct fuel is used.</li> <li>Ensure that the correct fuel is used.</li> </ul>
<p><b>Procedures during bunkering</b></p> <ul style="list-style-type: none"> <li>Monitor the amount of fuel.</li> <li>Check the amount of fuel to be bunkered.</li> <li>Check the amount of fuel to be bunkered.</li> </ul>	<p><b>Check</b></p> <ul style="list-style-type: none"> <li>Ensure that the correct fuel is used.</li> <li>Ensure that the correct fuel is used.</li> <li>Ensure that the correct fuel is used.</li> <li>Ensure that the correct fuel is used.</li> </ul>
<p><b>Procedures after bunkering</b></p> <ul style="list-style-type: none"> <li>Check the amount of fuel.</li> <li>Check the amount of fuel to be bunkered.</li> <li>Check the amount of fuel to be bunkered.</li> </ul>	<p><b>Check</b></p> <ul style="list-style-type: none"> <li>Ensure that the correct fuel is used.</li> <li>Ensure that the correct fuel is used.</li> <li>Ensure that the correct fuel is used.</li> <li>Ensure that the correct fuel is used.</li> </ul>

Safety procedures in compliance with the ISM Code

S 63 13

### Fire & Explosion

Crucial procedures

<p><b>Sound the alarm</b></p> <ul style="list-style-type: none"> <li>Use the alarm.</li> <li>Use the alarm.</li> <li>Use the alarm.</li> </ul>	<p><b>Immediate response</b></p> <ul style="list-style-type: none"> <li>Clear the area.</li> <li>Clear the area.</li> <li>Clear the area.</li> </ul>
<p><b>Limit the damage</b></p> <ul style="list-style-type: none"> <li>Close all windows and doors.</li> <li>Close all windows and doors.</li> <li>Close all windows and doors.</li> </ul>	<p><b>Evaluate the situation</b></p> <ul style="list-style-type: none"> <li>Check the situation.</li> <li>Check the situation.</li> <li>Check the situation.</li> </ul>
<p><b>Communicate</b></p> <ul style="list-style-type: none"> <li>Use the communication system.</li> <li>Use the communication system.</li> <li>Use the communication system.</li> </ul>	<p><b>Further actions in port</b></p> <ul style="list-style-type: none"> <li>Use the communication system.</li> <li>Use the communication system.</li> <li>Use the communication system.</li> </ul>

Safety procedures in compliance with the ISM Code

S 63 14



# Safety awareness and training procedures

## Health and safety operational procedures

(mm)  
400x300  
600x400



### Food Preparation & Storage

**ESSENTIAL FOOD PREPARATION TIPS**

**PREPARING FOOD FROM FROZEN**

**FOOD STORAGE**

**NEVER MIX RAW AND COOKED FOOD**

**COOKING AND HEATING**

**PACKAGE CHECKS**

© Everlux

S 63 23

### Kitchen Hygiene

**INTRODUCTION**

**1 WASHING UP**

**2 CLEANING MATERIALS**

**KEEPING YOUR KITCHEN CLEAN**

**3 WASTE DISPOSAL**

**4 PEST CONTROL**

© Everlux

S 63 24

### Preventing Slips, Trips & Falls

**KNOW THE RISKS**

**1 HAZARD | SPILLAGES**

**2 HAZARD | CABLES**

**3 HAZARD | OBSTRUCTIONS**

**4 HAZARD | FLOORING**

**5 HAZARD | FOOTWEAR**

**6 HAZARD | LIGHTING**

**7 PREVENTING ACCIDENTS**

© Everlux

S 63 25

### Safe Manual Handling

**INTRODUCTION**

**RISK ASSESSMENT**

**EMPLOYERS & EMPLOYEES**

**HANDLING TECHNIQUES**

© Everlux

S 63 26

### Stress Management

**1 WHAT IS STRESS?**

**2 REACTIONS TO STRESS**

**3 COPING WITH STRESS**

**4 THINK POSITIVELY**

**5 TIME MANAGEMENT**

**6 BALANCE WORK & FAMILY**

**7 COMMUNICATION**

**8 BREAKING THE CYCLE**

© Everlux

S 63 27

(mm)  
300x400  
400x600



### Do Not Discharge Garbage Overboard

You could be violating the law  
Any garbage discharge is to be recorded

MARPOL Anti-Pollution Regulations

Garbage Type	Plastic	Food Waste	General Waste	Oil	Other
Plastic	Prohibited	Prohibited	Prohibited	Prohibited	Prohibited
Food Waste	Prohibited	Prohibited	Prohibited	Prohibited	Prohibited
General Waste	Prohibited	Prohibited	Prohibited	Prohibited	Prohibited
Oil	Prohibited	Prohibited	Prohibited	Prohibited	Prohibited
Other	Prohibited	Prohibited	Prohibited	Prohibited	Prohibited

© Everlux

S 63 21

## Health and safety operational procedures

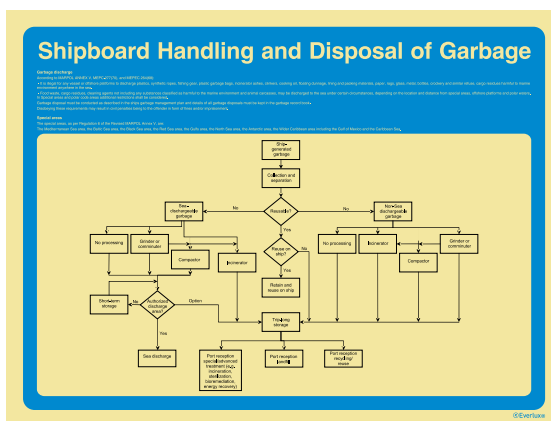
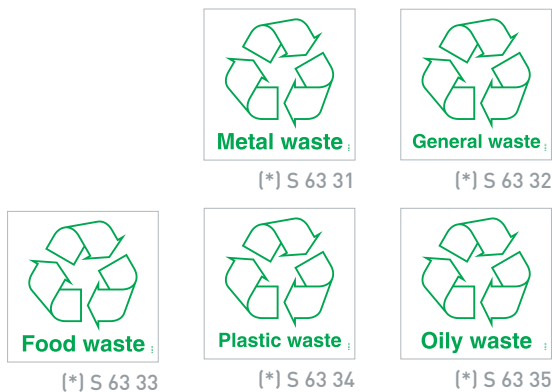

S 63 22

 (mm)  
 (\*) 150x150  
 400x300  
 600x400  
 (\*) Only available in this size



(\*)S 63 72

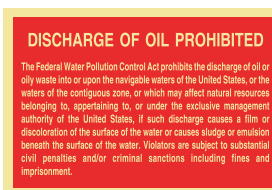

S 63 71

 (mm)  
 400x200  
 (\*) 300x200  
 (\*) Only available in this size

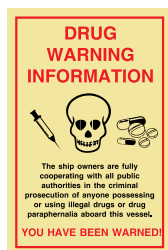

S 63 62



S 63 63

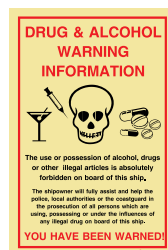

S 63 64

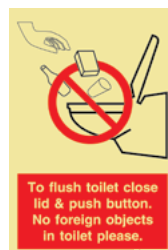

S 63 74

 (mm)  
 150x200  
 200x300





## Safety awareness and training procedures - Spanish speaking crews



S 64 01



S 64 02

 (mm)  
 300x400  
 400x600  
  
  
  

# Safety awareness and training procedures

## Safety awareness and training procedures - Spanish speaking crews

(mm)  
300x400  
400x600



### Puesta a Flote del Bote Salvavidas

Procedimiento de seguridad para poner a flote de los botes salvavidas abiertos/cerrados. Asegurarse que la flota está lista.

- Preparativos iniciales**
  - 1. Inspeccionar que el bote de salvavidas esté correctamente asegurado.
  - 2. Asegurarse que el bote de salvavidas esté correctamente asegurado.
  - 3. Asegurarse que el bote de salvavidas esté correctamente asegurado.
- Abrido hacia la cubierta de embarque**
  - 1. Abrir el bote de salvavidas.
  - 2. Asegurarse que el bote de salvavidas esté correctamente asegurado.
- Figar el bote a la cubierta**
  - 1. Asegurarse que el bote de salvavidas esté correctamente asegurado.
  - 2. Asegurarse que el bote de salvavidas esté correctamente asegurado.
- Embarque de pasajeros**
  - 1. Asegurarse que el bote de salvavidas esté correctamente asegurado.
  - 2. Asegurarse que el bote de salvavidas esté correctamente asegurado.
- Proceso de anclado**
  - 1. Asegurarse que el bote de salvavidas esté correctamente asegurado.
  - 2. Asegurarse que el bote de salvavidas esté correctamente asegurado.
- Separación del buque**
  - 1. Asegurarse que el bote de salvavidas esté correctamente asegurado.
  - 2. Asegurarse que el bote de salvavidas esté correctamente asegurado.

Procedimientos de seguridad de acuerdo con el Código ISM

©Everlux  
S 64 03

### Puesta a Flote de un Bote Salvavidas Totalmente Cerrados

Procedimientos para el lanzamiento de un bote salvavidas totalmente cerrado

- Medidas iniciales**
  - 1. Comprobar que el bote de salvavidas esté correctamente asegurado.
  - 2. Comprobar que el bote de salvavidas esté correctamente asegurado.
- Medidas para el lanzamiento**
  - 1. Comprobar que el bote de salvavidas esté correctamente asegurado.
  - 2. Comprobar que el bote de salvavidas esté correctamente asegurado.
- Anclado del bote salvavidas**
  - 1. Comprobar que el bote de salvavidas esté correctamente asegurado.
  - 2. Comprobar que el bote de salvavidas esté correctamente asegurado.
- Puesta a flote**
  - 1. Comprobar que el bote de salvavidas esté correctamente asegurado.
  - 2. Comprobar que el bote de salvavidas esté correctamente asegurado.
- Separación del buque**
  - 1. Comprobar que el bote de salvavidas esté correctamente asegurado.
  - 2. Comprobar que el bote de salvavidas esté correctamente asegurado.
- Medidas finales**
  - 1. Comprobar que el bote de salvavidas esté correctamente asegurado.
  - 2. Comprobar que el bote de salvavidas esté correctamente asegurado.

Procedimientos de seguridad de acuerdo con el Código ISM

©Everlux  
S 64 04

### Puesta a Flote de un Bote Salvavidas de Caída Libre

Consignas de seguridad para el lanzamiento de un bote salvavidas de caída libre

- Puesto de reunión**
  - 1. Asegurarse que el bote de salvavidas esté correctamente asegurado.
  - 2. Asegurarse que el bote de salvavidas esté correctamente asegurado.
- Reposos antes del lanzamiento**
  - 1. Asegurarse que el bote de salvavidas esté correctamente asegurado.
  - 2. Asegurarse que el bote de salvavidas esté correctamente asegurado.
- Operaciones del lanzamiento**
  - 1. Asegurarse que el bote de salvavidas esté correctamente asegurado.
  - 2. Asegurarse que el bote de salvavidas esté correctamente asegurado.
- Embarque**
  - 1. Asegurarse que el bote de salvavidas esté correctamente asegurado.
  - 2. Asegurarse que el bote de salvavidas esté correctamente asegurado.
- Lanzamiento**
  - 1. Asegurarse que el bote de salvavidas esté correctamente asegurado.
  - 2. Asegurarse que el bote de salvavidas esté correctamente asegurado.
- Medidas posteriores**
  - 1. Asegurarse que el bote de salvavidas esté correctamente asegurado.
  - 2. Asegurarse que el bote de salvavidas esté correctamente asegurado.

Procedimientos de seguridad de acuerdo con el Código ISM

©Everlux  
S 64 05

### Prevención de Derrames de Petróleo

Procedimientos para reducir la probabilidad de derrames de hidrocarburos

**AVISO:** El Reglamento de la Convención Internacional para la Prevención de la Contaminación por los Buques (MARPOL 73/78), para evitar la contaminación por los hidrocarburos, establece que los buques deben cumplir con el Reglamento de Prevención de Derrames de Petróleo (DPR) y el Reglamento de Prevención de Derrames de Petróleo (DPR).

- Conozca su buque**
  - 1. Asegurarse que el bote de salvavidas esté correctamente asegurado.
  - 2. Asegurarse que el bote de salvavidas esté correctamente asegurado.
- Tape los intercomunicadores**
  - 1. Asegurarse que el bote de salvavidas esté correctamente asegurado.
  - 2. Asegurarse que el bote de salvavidas esté correctamente asegurado.
- Utilice los equipos adecuados**
  - 1. Asegurarse que el bote de salvavidas esté correctamente asegurado.
  - 2. Asegurarse que el bote de salvavidas esté correctamente asegurado.
- Comunicaciones e identificación**
  - 1. Asegurarse que el bote de salvavidas esté correctamente asegurado.
  - 2. Asegurarse que el bote de salvavidas esté correctamente asegurado.
- Control pumping rate**
  - 1. Asegurarse que el bote de salvavidas esté correctamente asegurado.
  - 2. Asegurarse que el bote de salvavidas esté correctamente asegurado.
- Use barridos de grates**
  - 1. Asegurarse que el bote de salvavidas esté correctamente asegurado.
  - 2. Asegurarse que el bote de salvavidas esté correctamente asegurado.

Procedimientos de seguridad de acuerdo con el Código ISM

©Everlux  
S 64 06

### Señalización de Seguridad Según la Resolución OMI A.760(18) e ISO 17631

Procedimientos de seguridad, en conformidad con el Código ISM

©Everlux  
S 64 81

### Señalización de Control de Incendios OMI

Simbolos gráficos de control de incendios según la Resolución OMI A.654(16)

©Everlux  
S 64 82

## Safety awareness and training procedures - Spanish speaking crews

### ¡Hombre al Agua!

Procedimientos esenciales al descubrir un naufragio

**1 Medidas inmediatas - Cubierta**

Evitar el naufragio en un momento crítico de la huida y en las zonas de escape. No abandonar el puente de mando. No perder de vista al naufragio. Hacer alertas de naufragio.



**2 Medidas inmediatas - Puente de mando**

Alertar al puente y al puente auxiliar al largo (RIS) en caso de emergencia. Cuando sea posible parar el motor. Activar el sistema de alarma de agua para evitar la inundación y el naufragio (Sistema de alarma de agua). Informar al puente de mando de la situación. Informar al puente de mando de la situación. Informar al puente de mando de la situación.



**3 Soluciones iniciales - en el mar**

Informar al puente de mando de la situación. Informar al puente de mando de la situación. Informar al puente de mando de la situación. Informar al puente de mando de la situación. Informar al puente de mando de la situación.



**4 Soluciones iniciales - cuando está fondeado o en el puerto**

Utilizar el procedimiento de escape en caso de emergencia. Informar al puente de mando de la situación. Informar al puente de mando de la situación. Informar al puente de mando de la situación. Informar al puente de mando de la situation.



**3 Soluciones secundarias - si el naufragio no ha sido descubierto**

- Incrementar aún más las vigías.
- Empezar con las maniobras de búsqueda.
- Informar el centro de coordinación de salvamento más cercano y los buques en la zona.
- Mantener la búsqueda y reportar las avances de la situación.

Procedimientos de seguridad, en conformidad con el Código ISM

©Everlux®

S 64 83

### Luz, Forma y Señales Sonoras

Señales de comunicación internacionales

Reglamento y Búsqueda	Maniobra	Prisa	Exterior	Fuente de luz	Señales
Regla 18					
Regla 19					
Regla 20					
Regla 21					
Regla 22					
Regla 23					
Regla 24					
Regla 25					
Regla 26 a 27					

Procedimientos de seguridad, en conformidad con el Código ISM

©Everlux®

S 64 85

(mm)  
300x400  
400x600



### Disposición Requerida para el Embarque del Práctico

Según el Convenio SOLAS V/22 y la Resolución de IMO A.194(27)

**DISPOSICIÓN PARA BUQUES CON FRANCOBORDO IGUAL O MENOR A 9 METROS**



**DISPOSICIÓN PARA BUQUES CON FRANCOBORDO DE MÁS DE 9 METROS**

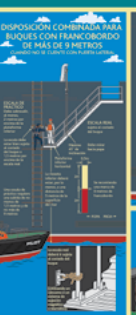

**4. CARRETE DEL CHIGRE DE LA ESCALA DEL PRÁCTICO**



Procedimientos de seguridad, en conformidad con el Código ISM

©Everlux®

S 64 84

### CARTEL DE LA PUENTE DE MANDO

Nombre del buque: \_\_\_\_\_ Nivel de alarma: \_\_\_\_\_ Tormenta de registro boca: \_\_\_\_\_ Tormenta de registro rojo: \_\_\_\_\_

Mas. Tumbados de desplazamiento: \_\_\_\_\_ toneladas de peso muerto. Coeficiente de bloque en el calado: \_\_\_\_\_ a plena carga en varcos.

DATOS DE EMERGENCIA		CADENA DE ANCLA	
¿Qué día se realizó?	¿Quién lo realizó?	¿Cuánta cadena?	¿Carga Límite de Tronera (en toneladas)?
¿Qué día se realizó?	¿Quién lo realizó?	¿Cuánta cadena?	¿Carga Límite de Tronera (en toneladas)?

DATOS DE LA PROPULSIÓN		EFECTOS DE LA PROPULSIÓN EN LAS OPERACIONES DEL ANCLAJE	
Estado del motor	Velocidad (nudos)	Propulsor	EF (FT)
Velocidad máxima admisible	Carbante	Protección	Protección
Acuerdo de velocidad	Latido	Purga	Purga
Acuerdo de potencia	Revoluciones mínimas	Compuerta	Compuerta

AUMENTO DE CALADO (CARGADO)		Efecto del latido	
Acuerdo de velocidad	Incremento del tiempo de respuesta	Incremento del tiempo de respuesta	Incremento del tiempo de respuesta
Acuerdo de potencia	Incremento del tiempo de respuesta	Incremento del tiempo de respuesta	Incremento del tiempo de respuesta

Procedimientos de seguridad, en conformidad con el Código ISM

©Everlux®

S 64 86

(mm)  
400x300  
600x400



### Abastecimiento de Combustible

Procedimientos de seguridad

**Procedimientos antes de abastecer**

Acciones: Verificar que el combustible sea el correcto. Verificar que el combustible sea el correcto. Verificar que el combustible sea el correcto.



**Procedimientos durante el abastecimiento**

Acciones: Tener cuidado de las bombas de combustible. Tener cuidado de las bombas de combustible. Tener cuidado de las bombas de combustible.



**Procedimientos después de abastecer**

Acciones: Limpiar el área de trabajo. Limpiar el área de trabajo. Limpiar el área de trabajo.



**Procedimientos de seguridad**

Acciones: Mantener el área de trabajo limpia. Mantener el área de trabajo limpia. Mantener el área de trabajo limpia.



Procedimientos de seguridad, en conformidad con el Código ISM

©Everlux®

S 64 87

### Choque Eléctrico, Ahogamiento o Lesiones Graves

Acciones a tomar en cuenta al descubrir una víctima de choque eléctrico, ahogamiento o accidente grave

**Choque eléctrico**

Acciones: Desconectar a la víctima de la fuente de energía. Desconectar a la víctima de la fuente de energía. Desconectar a la víctima de la fuente de energía.

**Ahogamiento**

Acciones: Realizar maniobras de reanimación. Realizar maniobras de reanimación. Realizar maniobras de reanimación.

**Lesiones graves**

Acciones: Realizar maniobras de reanimación. Realizar maniobras de reanimación. Realizar maniobras de reanimación.

**ABC de la reanimación Vías respiratorias-Respiración-Circulación**

**A Compruebe consciencia**



**B Compruebe respiración**



**C Compruebe el pulso**



**Reanimación**



Procedimientos de seguridad, en conformidad con el Código ISM

©Everlux®

S 64 88

(mm)  
300x400  
400x600





## Safety awareness and training procedures - French speaking crews

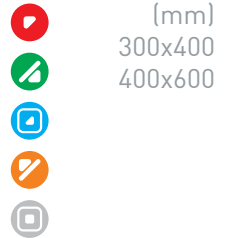

(mm)  
300x400  
400x600

### Lancement de bateau de sauvetage

Ouverture du lancement / procédures de sécurité canots de sauvetage semi-fermes. Assurez-vous que la ligne est équipée.

**1 Les premiers préparatifs**

- Assurez-vous que les câbles de halage sont serrés.
- Assurez-vous que les câbles de halage sont correctement installés.
- Assurez-vous que les câbles de halage sont correctement installés.

**2 Descendez au niveau du pont**

- Assurez-vous que les câbles de halage sont serrés.
- Assurez-vous que les câbles de halage sont correctement installés.
- Assurez-vous que les câbles de halage sont correctement installés.

**3 Fixation au pont d'embarquement**

- Assurez-vous que les câbles de halage sont serrés.
- Assurez-vous que les câbles de halage sont correctement installés.
- Assurez-vous que les câbles de halage sont correctement installés.

**4 Personnel à bord**

- Assurez-vous que les câbles de halage sont serrés.
- Assurez-vous que les câbles de halage sont correctement installés.
- Assurez-vous que les câbles de halage sont correctement installés.

**5 Descendez à l'eau**

- Assurez-vous que les câbles de halage sont serrés.
- Assurez-vous que les câbles de halage sont correctement installés.
- Assurez-vous que les câbles de halage sont correctement installés.

**6 Lâcher prise**

- Assurez-vous que les câbles de halage sont serrés.
- Assurez-vous que les câbles de halage sont correctement installés.
- Assurez-vous que les câbles de halage sont correctement installés.

*Ordonnez à l'équipage de rester à bord de la ligne et de rester à l'abri de la zone de sécurité.*

Procédures de sécurité en conformité avec le code ISM

©Everlux®

S 64 34

### Mise à l'eau du Bateau de Sauvotage Fermé Depuis son Arrimage

Procédures de lancement (Edition Soles 2004 consolidée chapitre III, règlement 23)

**1 Précautions**

- Assurez-vous que les câbles de halage sont serrés.
- Assurez-vous que les câbles de halage sont correctement installés.
- Assurez-vous que les câbles de halage sont correctement installés.

**2 Lancement des opérations**

- Assurez-vous que les câbles de halage sont serrés.
- Assurez-vous que les câbles de halage sont correctement installés.
- Assurez-vous que les câbles de halage sont correctement installés.

**3 Mise à l'eau**

- Assurez-vous que les câbles de halage sont serrés.
- Assurez-vous que les câbles de halage sont correctement installés.
- Assurez-vous que les câbles de halage sont correctement installés.

**4 Entrée dans l'eau**

- Assurez-vous que les câbles de halage sont serrés.
- Assurez-vous que les câbles de halage sont correctement installés.
- Assurez-vous que les câbles de halage sont correctement installés.

**5 Départ**

- Assurez-vous que les câbles de halage sont serrés.
- Assurez-vous que les câbles de halage sont correctement installés.
- Assurez-vous que les câbles de halage sont correctement installés.

**6 Procédures finales**

- Assurez-vous que les câbles de halage sont serrés.
- Assurez-vous que les câbles de halage sont correctement installés.
- Assurez-vous que les câbles de halage sont correctement installés.

Procédures de sécurité en conformité avec le Code ISM

©Everlux®

S 64 35

### Opération rapide de sauvotage de bateau

SOLAS Chapitre III / MSC Circulaire 1161

**1 Préparation**

- Assurez-vous que les câbles de halage sont serrés.
- Assurez-vous que les câbles de halage sont correctement installés.
- Assurez-vous que les câbles de halage sont correctement installés.

**2 Lancement**

- Assurez-vous que les câbles de halage sont serrés.
- Assurez-vous que les câbles de halage sont correctement installés.
- Assurez-vous que les câbles de halage sont correctement installés.

**3 Préparer le navire**

- Assurez-vous que les câbles de halage sont serrés.
- Assurez-vous que les câbles de halage sont correctement installés.
- Assurez-vous que les câbles de halage sont correctement installés.

**4 Procédures d'urgence**

- Assurez-vous que les câbles de halage sont serrés.
- Assurez-vous que les câbles de halage sont correctement installés.
- Assurez-vous que les câbles de halage sont correctement installés.

**5 Sauvetage des survivants**

- Assurez-vous que les câbles de halage sont serrés.
- Assurez-vous que les câbles de halage sont correctement installés.
- Assurez-vous que les câbles de halage sont correctement installés.

**6 Retourner sur le bateau**

- Assurez-vous que les câbles de halage sont serrés.
- Assurez-vous que les câbles de halage sont correctement installés.
- Assurez-vous que les câbles de halage sont correctement installés.

Procédures de sécurité en conformité avec le code ISM

©Everlux®

S 64 36

### Ravitaillement

Procédures de sécurité

**Procédures avant le ravitaillement**

**Actions:**

- Assurez-vous que les câbles de halage sont serrés.
- Assurez-vous que les câbles de halage sont correctement installés.
- Assurez-vous que les câbles de halage sont correctement installés.

**Vérifier:**

- Assurez-vous que les câbles de halage sont serrés.
- Assurez-vous que les câbles de halage sont correctement installés.
- Assurez-vous que les câbles de halage sont correctement installés.

**Procédures durant le ravitaillement**

**Actions:**

- Assurez-vous que les câbles de halage sont serrés.
- Assurez-vous que les câbles de halage sont correctement installés.
- Assurez-vous que les câbles de halage sont correctement installés.

**Vérifier:**

- Assurez-vous que les câbles de halage sont serrés.
- Assurez-vous que les câbles de halage sont correctement installés.
- Assurez-vous que les câbles de halage sont correctement installés.

**Procédures après le ravitaillement**

**Actions:**

- Assurez-vous que les câbles de halage sont serrés.
- Assurez-vous que les câbles de halage sont correctement installés.
- Assurez-vous que les câbles de halage sont correctement installés.

**Vérifier:**

- Assurez-vous que les câbles de halage sont serrés.
- Assurez-vous que les câbles de halage sont correctement installés.
- Assurez-vous que les câbles de halage sont correctement installés.

Procédures de sécurité en conformité avec le code ISM

©Everlux®

S 64 37

### Chute Libre de L'embarcation de Sauvetage

Procédures

**1 Rassemblement de l'équipage**

- Assurez-vous que les câbles de halage sont serrés.
- Assurez-vous que les câbles de halage sont correctement installés.
- Assurez-vous que les câbles de halage sont correctement installés.

**2 Vérifiez avant le lancement**

- Assurez-vous que les câbles de halage sont serrés.
- Assurez-vous que les câbles de halage sont correctement installés.
- Assurez-vous que les câbles de halage sont correctement installés.

**3 Actions du Timonier**

- Assurez-vous que les câbles de halage sont serrés.
- Assurez-vous que les câbles de halage sont correctement installés.
- Assurez-vous que les câbles de halage sont correctement installés.

**4 Embarkement**

- Assurez-vous que les câbles de halage sont serrés.
- Assurez-vous que les câbles de halage sont correctement installés.
- Assurez-vous que les câbles de halage sont correctement installés.

**5 Lancement**

- Assurez-vous que les câbles de halage sont serrés.
- Assurez-vous que les câbles de halage sont correctement installés.
- Assurez-vous que les câbles de halage sont correctement installés.

**6 Autres actions**

- Assurez-vous que les câbles de halage sont serrés.
- Assurez-vous que les câbles de halage sont correctement installés.
- Assurez-vous que les câbles de halage sont correctement installés.

Procédures de sécurité en conformité avec le code ISM

©Everlux®

S 64 70

### Signaux Lumineux, de Formes & Auditifs

Signaux de communication internationale

Signal et couleur	Port	Est avant	Tribord	Forme de pont	Don
Signal M					
Signal N					
Signal O					
Signal P					
Signal Q					
Signal R					
Signal S					
Signal T					
Signal U					
Signal V					
Signal W					
Signal X					
Signal Y					
Signal Z					
Signal AA					
Signal AB					
Signal AC					
Signal AD					
Signal AE					
Signal AF					
Signal AG					
Signal AH					
Signal AI					
Signal AJ					
Signal AK					
Signal AL					
Signal AM					
Signal AN					
Signal AO					
Signal AP					
Signal AQ					
Signal AR					
Signal AS					
Signal AT					
Signal AU					
Signal AV					
Signal AW					
Signal AX					
Signal AY					
Signal AZ					
Signal BA					
Signal BB					
Signal BC					
Signal BD					
Signal BE					
Signal BF					
Signal BG					
Signal BH					
Signal BI					
Signal BJ					
Signal BK					
Signal BL					
Signal BM					
Signal BN					
Signal BO					
Signal BP					
Signal BQ					
Signal BR					
Signal BS					
Signal BT					
Signal BU					
Signal BV					
Signal BW					
Signal BX					
Signal BY					
Signal BZ					
Signal CA					
Signal CB					
Signal CC					
Signal CD					
Signal CE					
Signal CF					
Signal CG					
Signal CH					
Signal CI					
Signal CJ					
Signal CK					
Signal CL					
Signal CM					
Signal CN					
Signal CO					
Signal CP					
Signal CQ					
Signal CR					
Signal CS					
Signal CT					
Signal CU					
Signal CV					
Signal CW					
Signal CX					
Signal CY					
Signal CZ					
Signal DA					
Signal DB					
Signal DC					
Signal DD					
Signal DE					
Signal DF					
Signal DG					
Signal DH					
Signal DI					
Signal DJ					
Signal DK					
Signal DL					
Signal DM					
Signal DN					
Signal DO			<		

# Safety awareness and training procedures

## Safety awareness and training procedures - French speaking crews

(mm)  
300x400  
400x600  
400x300(\*)  
600x400(\*)



### Passerelles de Débarquement

Sécurisez le gréement et utilisez les passerelles

- 1** Assurez-vous que le gréement de la passerelle est bien attaché et sécurisé.
- 2** Assurez-vous que le fil de fer de la passerelle est bien attaché et sécurisé.
- 3** Assurez-vous que la passerelle est bien attachée et sécurisée.
- 4** Assurez-vous que la passerelle est bien attachée et sécurisée.
- 5** Assurez-vous que la passerelle est bien attachée et sécurisée.
- 6** Assurez-vous que la passerelle est bien attachée et sécurisée.

Procédures de sécurité en conformité avec le code ISM

S 64 73

### Amarrage

Procédures de sécurité d'amarrage et de largage

- 1 Avant d'arriver**  
Assurez-vous que le gréement de la passerelle est bien attaché et sécurisé.
- 2 Embarrquement du pilote**  
Assurez-vous que le pilote est bien attaché et sécurisé.
- 3 À l'arrivée des remorqueurs**  
Assurez-vous que les remorqueurs sont bien attachés et sécurisés.
- 4 Pendant l'amarrage**  
Assurez-vous que l'amarrage est bien effectué et sécurisé.
- 5 Surveillez les amarres**  
Assurez-vous que les amarres sont bien surveillées et sécurisées.
- 6 Largeur des amarres**  
Assurez-vous que la largeur des amarres est bien contrôlée et sécurisée.

Procédures de sécurité en conformité avec le code ISM

S 64 75

### Remorquage

Procédures de sécurité recommandées pour les opérations de remorquage

ACTIONS de REMORQUAGE	ACTIONS du NAVIRE
<b>1 A faire rapidement</b> Assurez-vous que le remorquage est bien effectué et sécurisé.	<b>1 A faire rapidement</b> Assurez-vous que le navire est bien sécurisé et prêt pour le remorquage.
<b>2 Remorquage au tirage</b> Assurez-vous que le tirage est bien effectué et sécurisé.	<b>2 Remorquage</b> Assurez-vous que le navire est bien sécurisé et prêt pour le remorquage.
<b>3 Lâcher grappe</b> Assurez-vous que la grappe est bien lâchée et sécurisée.	<b>3 Lâcher grappe</b> Assurez-vous que la grappe est bien lâchée et sécurisée.

Procédures de sécurité en conformité avec le code ISM

S 64 74

### Dispositifs D'embarquement Requis pour le Pilote

Diagrammes et illustrations des dispositifs d'embarquement requis pour le pilote, y compris les échelles de pilote et les dispositifs combinés pour les navires franc-bord.

(\*) S 64 71

### Prévention des Déversements D'hydrocarbures

Procédures pour réduire les risques de déversements d'hydrocarbures

- 1 Apprenez à connaître votre navire**  
Assurez-vous de connaître les points de déversement et les procédures de sécurité.
- 2 Bouchoirs d'arrêt**  
Assurez-vous que les bouchoirs d'arrêt sont bien installés et sécurisés.
- 3 Communications and identification**  
Assurez-vous que les communications et l'identification sont bien effectuées et sécurisées.
- 4 Contrôlez le débit de pompage**  
Assurez-vous que le débit de pompage est bien contrôlé et sécurisé.
- 5 Utilisez des bacs de rétention**  
Assurez-vous que les bacs de rétention sont bien utilisés et sécurisés.

Procédures de sécurité en conformité avec le code ISM

S 64 76

### Soudage & Oxycochage

Procédures de sécurité lors des opérations de soudage

- 1 Général**  
Assurez-vous que les procédures de sécurité générales sont bien suivies et sécurisées.
- 2 Vérifier de protection**  
Assurez-vous que les équipements de protection sont bien vérifiés et sécurisés.
- 3 Précautions contre les incendies et explosions**  
Assurez-vous que les précautions contre les incendies et explosions sont bien prises et sécurisées.
- 4 Précautions à prendre pendant le soudage**  
Assurez-vous que les précautions à prendre pendant le soudage sont bien prises et sécurisées.
- 5 Précautions à prendre pendant le soudage et le découpage du gaz**  
Assurez-vous que les précautions à prendre pendant le soudage et le découpage du gaz sont bien prises et sécurisées.

Procédures de sécurité en conformité avec le code ISM

S 64 77

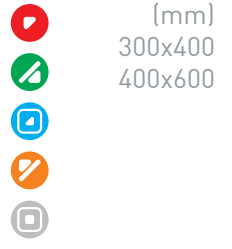

(mm)  
300x400  
400x600

### Équipement de Protection Individuelle

Choisir le bon équipement de sécurité individuel

**1 Protection de la tête**  
Porter un casque de protection approprié en fonction de l'activité et de l'environnement de travail.

**2 Protection respiratoire**  
Porter un appareil respiratoire approprié en fonction de l'activité et de l'environnement de travail.

**3 Protection des yeux**  
Porter des lunettes de protection appropriées en fonction de l'activité et de l'environnement de travail.

**4 Protection de la peau**  
Porter des vêtements de protection appropriés en fonction de l'activité et de l'environnement de travail.

**5 Protection des mains**  
Porter des gants de protection appropriés en fonction de l'activité et de l'environnement de travail.

**6 Protection des pieds**  
Porter des chaussures de protection appropriées en fonction de l'activité et de l'environnement de travail.

**7 Équipement spécialisé**  
Porter l'équipement spécialisé approprié en fonction de l'activité et de l'environnement de travail.

Procédures de sécurité en conformité avec le code ISM

S 64 78

### Appareil Respiratoire Isolant

Mesures de sécurité d'utilisation dans des conditions dangereuses

**1 Vérifier chaque semaine et avant utilisation**  
Vérifier l'état de l'appareil, la date de validité et les instructions d'utilisation.

**2 Préparer l'appareil respiratoire**  
Placer le cylindre dans le support, serrer le cylindre, vérifier les connexions.

**3 Réglementation et vérification des fonctions**  
Vérifier le niveau de l'huile, la date de validité, la date de la dernière vérification.

**4 Démarrer l'opération**  
Vérifier le niveau de l'huile, la date de validité, la date de la dernière vérification.

Procédures de sécurité en conformité avec le code ISM

S 64 79

### Hygiène Alimentaire à Bord du Navire

Procédures de santé et sécurité recommandées dans les garde-manger, cuisines et congélateurs

**1 Santé et Hygiène**  
Porter des vêtements propres et propres, utiliser des produits d'hygiène personnelle.

**2 La préparation des aliments**  
Porter des vêtements propres et propres, utiliser des produits d'hygiène personnelle.

**3 Contrôle de la température**  
Vérifier la température des aliments, utiliser des thermomètres.

**4 Les glaces, les chutes et les risques de chute**  
Porter des chaussures de sécurité, utiliser des produits d'hygiène personnelle.

Procédures de sécurité en conformité avec le code ISM

S 64 80

### Ne Pas Jeter D'ordures Dans L'eau

Vous pouvez être en train d'enfreindre la loi  
Toute élimination de déchets doit être enregistrée

MARPOL Réglementations anti-pollution

Type de déchets	Zone A	Zone B	Zone C	Zone D
Ordures solides	Interdiction	Interdiction	Interdiction	Interdiction
Ordures liquides	Interdiction	Interdiction	Interdiction	Interdiction
Ordures gazeuses	Interdiction	Interdiction	Interdiction	Interdiction
Ordures solides dissolvables	Interdiction	Interdiction	Interdiction	Interdiction
Ordures solides non dissolvables	Interdiction	Interdiction	Interdiction	Interdiction
Ordures liquides dissolvables	Interdiction	Interdiction	Interdiction	Interdiction
Ordures liquides non dissolvables	Interdiction	Interdiction	Interdiction	Interdiction
Ordures gazeuses dissolvables	Interdiction	Interdiction	Interdiction	Interdiction
Ordures gazeuses non dissolvables	Interdiction	Interdiction	Interdiction	Interdiction

Si vous n'êtes pas sûr, ne jetez pas d'ordures par-dessus le bord.

S 64 90

### Code International des Signaux Signalisation des Drapeaux

Alphabet	Alphabet	Alphabet
A	N	1
B	O	2
C	P	3
D	Q	4
E	R	5
F	S	6
G	T	7
H	U	8
I	V	9
J	W	0
K	X	
L	Y	
M	Z	

Procédures de sécurité en conformité avec le code ISM

S 64 61

### Signaux de Sauvetage

Signaux de communication internationale de recherche et de sauvetage selon les règlements SOLAS

**1 Signaux de recherche et de sauvetage**

**2 Signaux de sauvetage**

**3 Signaux de sauvetage**

**4 Signaux de sauvetage**

**5 Signaux de sauvetage**

**6 Signaux de sauvetage**

**7 Signaux de sauvetage**

**8 Signaux de sauvetage**

**9 Signaux de sauvetage**

**0 Signaux de sauvetage**

Procédures de sécurité en conformité avec le code ISM

S 64 62

(mm)  
300x400  
400x600



### Trabalho em Altura ou Fora de Bordo

#### Esteja ciente dos riscos ao trabalhar fora de bordo e em altura

**1 Preparação**  
Antes de qualquer trabalho em altura ou fora de bordo, o pessoal deve ser devidamente treinado e autorizado para tal. O trabalho em altura ou fora de bordo deve ser realizado de acordo com os procedimentos de segurança estabelecidos e com o Código ISM.

**2 Identificação do risco**  
A Estabelecer o risco  
B Avaliar o risco  
C Reduzir o risco  
D Comunicar o risco  
E Monitorizar o risco

**3 Instruções**  
As instruções devem ser dadas em português claro e simples, compreensíveis para todos os envolvidos. As instruções devem ser dadas em português claro e simples, compreensíveis para todos os envolvidos. As instruções devem ser dadas em português claro e simples, compreensíveis para todos os envolvidos.

**4 Trabalho em altura**  
Trabalhar em altura deve ser realizado de acordo com os procedimentos de segurança estabelecidos e com o Código ISM. O trabalho em altura deve ser realizado de acordo com os procedimentos de segurança estabelecidos e com o Código ISM.

**5 Trabalho fora de bordo**  
Trabalhar fora de bordo deve ser realizado de acordo com os procedimentos de segurança estabelecidos e com o Código ISM. O trabalho fora de bordo deve ser realizado de acordo com os procedimentos de segurança estabelecidos e com o Código ISM.

Procedimentos de segurança em conformidade com o Código ISM

©Everlux

S 64 50

### Segurança com Garrafas de Gás

#### Manuseamento seguro, armazenamento e práticas operacionais

**1 Garrafas de gás utilizadas em navios**  
As garrafas de gás utilizadas em navios devem ser devidamente identificadas e rotuladas. As garrafas de gás utilizadas em navios devem ser devidamente identificadas e rotuladas. As garrafas de gás utilizadas em navios devem ser devidamente identificadas e rotuladas.

**2 Procedimentos de segurança de manuseamento**  
O manuseamento das garrafas de gás deve ser realizado de acordo com os procedimentos de segurança estabelecidos e com o Código ISM. O manuseamento das garrafas de gás deve ser realizado de acordo com os procedimentos de segurança estabelecidos e com o Código ISM.

**3 Procedimentos de segurança de armazenamento**  
O armazenamento das garrafas de gás deve ser realizado de acordo com os procedimentos de segurança estabelecidos e com o Código ISM. O armazenamento das garrafas de gás deve ser realizado de acordo com os procedimentos de segurança estabelecidos e com o Código ISM.

Procedimentos de segurança em conformidade com o Código ISM

©Everlux

S 64 51

### Afogamento e Hipotermia

#### Ações a desenvolver ao descobrir uma vítima de afogamento ou hipotermia

**1 Afogamento**  
O afogamento ocorre quando uma pessoa se encontra submersa em água e não consegue respirar. O afogamento ocorre quando uma pessoa se encontra submersa em água e não consegue respirar. O afogamento ocorre quando uma pessoa se encontra submersa em água e não consegue respirar.

**2 Hipotermia**  
A hipotermia ocorre quando a temperatura corporal de uma pessoa cai abaixo de 35°C. A hipotermia ocorre quando a temperatura corporal de uma pessoa cai abaixo de 35°C. A hipotermia ocorre quando a temperatura corporal de uma pessoa cai abaixo de 35°C.

**3 Suporte Básico de Vida (SBV) (CoSTRA 2005)**  
O Suporte Básico de Vida (SBV) é um conjunto de procedimentos de primeiros socorros que devem ser realizados em caso de afogamento ou hipotermia. O Suporte Básico de Vida (SBV) é um conjunto de procedimentos de primeiros socorros que devem ser realizados em caso de afogamento ou hipotermia.

Procedimentos de segurança em conformidade com o Código ISM

©Everlux

S 64 52

### Choques Elétricos e Lesões Graves

#### Durante os primeiros minutos de uma paragem respiratória que não seja causada por afogamento, a ventilação, assim sendo, é fundamentalmente importante do que as compressões torácicas

**1 Choques elétricos**  
Os choques elétricos podem causar lesões graves, incluindo a morte. Os choques elétricos podem causar lesões graves, incluindo a morte. Os choques elétricos podem causar lesões graves, incluindo a morte.

**2 Lesões graves**  
As lesões graves podem causar a morte ou a incapacidade permanente. As lesões graves podem causar a morte ou a incapacidade permanente. As lesões graves podem causar a morte ou a incapacidade permanente.

**3 Suporte Básico de Vida (SBV) (CoSTRA 2005)**  
O Suporte Básico de Vida (SBV) é um conjunto de procedimentos de primeiros socorros que devem ser realizados em caso de afogamento ou hipotermia. O Suporte Básico de Vida (SBV) é um conjunto de procedimentos de primeiros socorros que devem ser realizados em caso de afogamento ou hipotermia.

Procedimentos de segurança em conformidade com o Código ISM

©Everlux

S 64 60

### Lançamento de balsa salvavidas

#### Procedimentos para o lançamento de balsas salva-vidas infláveis

**1 Ativação automática**  
A ativação automática da balsa salvavidas ocorre quando a balsa é lançada de bordo. A ativação automática da balsa salvavidas ocorre quando a balsa é lançada de bordo.

**2 Ativação manual**  
A ativação manual da balsa salvavidas ocorre quando a balsa é lançada de bordo. A ativação manual da balsa salvavidas ocorre quando a balsa é lançada de bordo.

**3 Lançamento da balsa salvavidas**  
O lançamento da balsa salvavidas deve ser realizado de acordo com os procedimentos de segurança estabelecidos e com o Código ISM. O lançamento da balsa salvavidas deve ser realizado de acordo com os procedimentos de segurança estabelecidos e com o Código ISM.

**4 Injeção de ar na balsa salvavidas**  
A injeção de ar na balsa salvavidas deve ser realizada de acordo com os procedimentos de segurança estabelecidos e com o Código ISM. A injeção de ar na balsa salvavidas deve ser realizada de acordo com os procedimentos de segurança estabelecidos e com o Código ISM.

Procedimentos de segurança em conformidade com o Código ISM

©Everlux

S 64 53

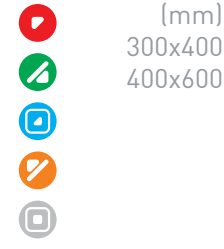

(mm)  
300x400  
400x600

### Balsas Salva-vidas Infláveis

Procedimentos essenciais após o lançamento à água

- Inverter a balsa salva-vidas para cima**  
 1. Inverter a balsa salva-vidas para cima.  
 2. Não se apoiar no lado exterior da balsa.  
 3. Não se apoiar no lado exterior da balsa.  
 4. Não se apoiar no lado exterior da balsa.
- Embarque rapidamente**  
 1. Embarque rapidamente.  
 2. Não se apoiar no lado exterior da balsa.  
 3. Não se apoiar no lado exterior da balsa.
- Afastar do navio**  
 1. Afastar do navio.  
 2. Não se apoiar no lado exterior da balsa.  
 3. Não se apoiar no lado exterior da balsa.
- Lançar a âncora**  
 1. Lançar a âncora.  
 2. Não se apoiar no lado exterior da balsa.  
 3. Não se apoiar no lado exterior da balsa.
- Fechar as embocas**  
 1. Fechar as embocas.  
 2. Não se apoiar no lado exterior da balsa.  
 3. Não se apoiar no lado exterior da balsa.
- Medidas posteriores**  
 1. Medidas posteriores.  
 2. Não se apoiar no lado exterior da balsa.  
 3. Não se apoiar no lado exterior da balsa.

Procedimento de segurança em conformidade com o Código ISM

©Everluxo  
S 64 54

### Lançamento da Baleeira em Condições Atmosféricas Perigosas

Procedimentos de segurança

- Confirmação de rumo para área segura**  
 1. Confirmação de rumo para área segura.  
 2. Não se apoiar no lado exterior da balsa.  
 3. Não se apoiar no lado exterior da balsa.
- Como preparar**  
 1. Como preparar.  
 2. Não se apoiar no lado exterior da balsa.  
 3. Não se apoiar no lado exterior da balsa.
- Início e abastecimento de ar para climatização e motor**  
 1. Início e abastecimento de ar para climatização e motor.  
 2. Não se apoiar no lado exterior da balsa.  
 3. Não se apoiar no lado exterior da balsa.
- Lançamento e início do sistema de ignição**  
 1. Lançamento e início do sistema de ignição.  
 2. Não se apoiar no lado exterior da balsa.  
 3. Não se apoiar no lado exterior da balsa.
- Designar-se para zona segura**  
 1. Designar-se para zona segura.  
 2. Não se apoiar no lado exterior da balsa.  
 3. Não se apoiar no lado exterior da balsa.
- Informação relevante**  
 1. Informação relevante.  
 2. Não se apoiar no lado exterior da balsa.  
 3. Não se apoiar no lado exterior da balsa.

Procedimento de segurança de acordo ao código ISM

©Everluxo  
S 64 55

### Higiene dos Alimentos a Bordo

Recomendações de saúde e segurança em copas, cozinhas e frigoríficos

- Saúde e higiene**  
 1. Saúde e higiene.  
 2. Não se apoiar no lado exterior da balsa.  
 3. Não se apoiar no lado exterior da balsa.
- Preparação dos alimentos**  
 1. Preparação dos alimentos.  
 2. Não se apoiar no lado exterior da balsa.  
 3. Não se apoiar no lado exterior da balsa.
- Equipamento de cozinha e limpeza**  
 1. Equipamento de cozinha e limpeza.  
 2. Não se apoiar no lado exterior da balsa.  
 3. Não se apoiar no lado exterior da balsa.
- Controlo de temperatura**  
 1. Controlo de temperatura.  
 2. Não se apoiar no lado exterior da balsa.  
 3. Não se apoiar no lado exterior da balsa.
- Limpeza, desinfeção e teste de armazenamento**  
 1. Limpeza, desinfeção e teste de armazenamento.  
 2. Não se apoiar no lado exterior da balsa.  
 3. Não se apoiar no lado exterior da balsa.

Procedimento de segurança de acordo ao código ISM

©Everluxo  
S 64 56

### Sinais de Salvamento

Sinais de comunicação internacional de busca e salvamento de acordo com os requerimentos SOLAS

Table with 4 columns: Signal, Description, Action, and Remarks.

Procedimento de segurança em conformidade com o Código ISM

©Everluxo  
S 64 57

### Colocação do Colete Salva-vidas

Instruções para colocar o colete Salva-vidas

- Coloque e coloque dentro da abertura**  
 1. Coloque e coloque dentro da abertura.  
 2. Não se apoiar no lado exterior da balsa.  
 3. Não se apoiar no lado exterior da balsa.
- Conecte o cinto à volta da cintura e conecte a fivela**  
 1. Conecte o cinto à volta da cintura e conecte a fivela.  
 2. Não se apoiar no lado exterior da balsa.  
 3. Não se apoiar no lado exterior da balsa.
- Ajuste a parte superior do colete Salva-vidas**  
 1. Ajuste a parte superior do colete Salva-vidas.  
 2. Não se apoiar no lado exterior da balsa.  
 3. Não se apoiar no lado exterior da balsa.
- Active a luz do colete Salva-vidas**  
 1. Active a luz do colete Salva-vidas.  
 2. Não se apoiar no lado exterior da balsa.  
 3. Não se apoiar no lado exterior da balsa.

Procedimento de segurança em conformidade com o Código ISM

©Everluxo  
S 64 58

### Sinais de Luzes, Formatos e Sons

Sinais de comunicação internacional

Table with 4 columns: Signal, Description, Action, and Remarks.

Procedimento de segurança em conformidade com o Código ISM

©Everluxo  
S 64 59

# General safety awareness notices

## Safety awareness

(mm)  
300x400  
400x600



**Safety First**  
Confined Spaces

Unless you know, avoid down below  
Use the correct PPE & procedures!

©Everlux

S 65 01

**Safety First**  
Electrical Safety

Be the only bright spark around  
Think electrical safety!

©Everlux

S 65 02

**Safety First**  
Eye Protection

To see or not to see, that is the question  
Use eye protection!

©Everlux

S 65 03

**Safety First**  
Fire Prevention

Play your part  
Be fire smart!

©Everlux

S 65 04

**Safety First**  
Follow Correct Procedures

Informed is better than deformed!

©Everlux

S 65 05

**Safety First**  
Hazardous Materials

Safety is as simple as ABC  
Always Be Careful and follow the instructions

©Everlux

S 65 06

**Safety First**  
Housekeeping

Avoid a scene  
Keep it clean!

©Everlux

S 65 07

**Safety First**  
Lift Correctly

Keep safety on track  
Look after your back!

©Everlux

S 65 08

**Safety First**  
Noise

Hear today, gone tomorrow  
Use hearing protection!

©Everlux

S 65 09

**Safety First**  
Personal Protective Equipment (PPE)

No safety know pain, know safety no pain  
Use the correct PPE!

©Everlux

S 65 10

**Safety First**  
Seek Medical Attention

A wound neglected is a wound infected  
Seek medical attention!

©Everlux

S 65 11

**Safety First**  
Slips and Falls

A spill, a slip  
A hospital trip!

©Everlux

S 65 12

The ©Everlux® general awareness safety notices can be used to remind the crew of the basic safety principles in order to create a safe environment on board.

When used together with the ©Everlux® safety awareness training procedures they will help you to comply with the ISM Code requirements

Deck safety plan

**EMERGENCY INSTRUCTION NOTICE FOR PASSENGERS**

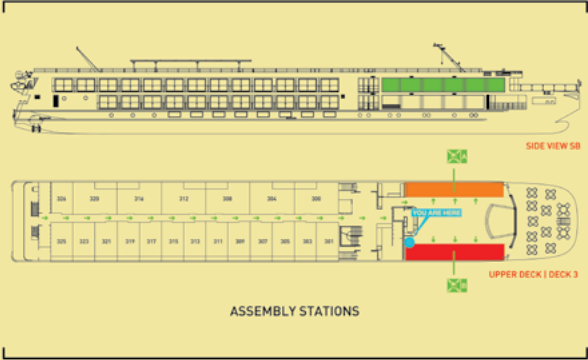

**ASSEMBLY STATIONS**

**YOU ARE HERE  
USTED ESTÁ AQUÍ**

**GENERAL EMERGENCY ALARM SIGNAL**  
In the event of an Emergency the following signal will be sounded on the Ship's Whistle and on the Public Address System:  
**SEVEN (7) short blasts followed by one (1) long blast of the Ship's Whistle supplemented by the same signal over the Loudspeakers.**

**ACTION ON HEARING THE GENERAL EMERGENCY SIGNAL**  
On hearing the General Emergency Alarm Signal:  
1. Proceed directly to your Assembly Station if you are in a location remote from your cabin.  
2. If you are in your cabin or close to your cabin when the signal is heard, dress warmly, collect your Luggage and any wearable medication and follow the Direction Signs to your Assembly Station.  
3. Assist those who need help.  
4. Follow the instructions of Crew Members and those given over the Public Address System.  
5. DO NOT return to your cabin to collect your property.  
6. DO NOT use lifts and  
7. If the Primary Escape is blocked, use the Secondary Escape which is shown by a dotted arrow, as marked on the plan above.

**ASSEMBLY STATIONS**  
An Assembly Station is a space where passengers assemble when the General Alarm Signal has been sounded. The Assembly Stations of the ship are located on Deck 3.

**ACTIONS ON ARRIVAL AT THE ASSEMBLY STATION**  
Stay calm and follow the instructions of the Crew Members at your Assembly Station.  
- Put on your Luggage, if you do not have a Luggage Crew Members will obtain one for you.

**LOW LOCATION LIGHTING**  
In event of an Emergency, a Low Level Outdoors System will be activated. It consists of a Lighted Strip placed one floor below your cabin.  
Follow the Lighted Strip if it lead you to an Exit.  
If there is smoke in the corridor, keep close to the floor and crawl, if necessary, to avoid breathing the smoke, and to see more clearly.

**IF YOU SEE SMOKE OR SMALL BURNING**  
Inform the ship's personnel immediately.

**MAN OVERBOARD**  
If you see someone fall overboard throw a lifebuoy and inform immediately the ship's personnel.

**SEÑAL DE EMERGENCIA GENERAL**  
En caso de Emergencia la siguiente señal será producida por los Soneros del Buque y por los Altavoces:  
**SEVEN (7) short blasts followed by one (1) long blast of the Siren de Buque y repetida por los Altavoces.**

**ACCIONES DE SEGUIR AL OIR LA SEÑAL DE EMERGENCIA GENERAL**  
Al oír la Señal de Emergencia General:  
1. Si se encuentra en un lugar lejano de su camarote, diríjase directamente a la Estación de reunión correspondiente.  
2. Si se encuentra en su camarote o en un lugar cerca de este, cuando la señal sea transmitida, póngase ropa que mantenga el calor, tome su Chaqueta Salvavidas y cualquier medicación que le sea indispensable y siga las señales que le indiquen el camino para llegar a la Estación de reunión.  
3. Ayude a quien lo necesite.  
4. Siga las instrucciones de los Tripulantes y las instrucciones por los Altavoces.  
5. NO regrese a su camarote para recoger objetos personales.  
6. NO utilice los ascensores.  
7. Si la salida Principal se encuentra bloqueada, utilice la Salida Secundaria (marcada con una línea punteada).

**ESTACIÓN DE REUNIÓN (ASSEMBLY STATION)**  
Una Estación de Reunión es un punto en el cual los pasajeros se reúnen en caso de Emergencia. Las estaciones de reunión (Assembly Station) se encuentran en el Puente 3.

**ACCIONES DE SEGUIR CUANDO LLEGUE A SU ESTACIÓN DE REUNIÓN**  
Permanezca tranquilo y siga las instrucciones de los Tripulantes en la Estación de Reunión.  
- Póngase su Chaqueta Salvavidas, Si no tiene Chaqueta Salvavidas, pídale a un Miembro de la Tripulación.

**GUÍAS LUMINOSAS**  
En caso de Emergencia, se activará un sistema luminoso. Este sistema consiste en una cinta luminosa puesta en el pasillo sobre el suelo. Siga el sistema luminoso hasta llegar a una Salida. En caso de humo en los pasillos, cúbale la cabeza y, si es necesario, no más cerca posible del suelo, para evitar de inhalar el humo y para tener mejor visibilidad.

**EN CASO DE HUMO U OLORES DE QUEIMADO**  
Evite inmediatamente al personal del buque.

**HOMBRE AL AGUA**  
Si usted ve caer una persona en el agua lance inmediatamente un salvavidas y avise al personal del buque.



(mm)  
300x400  
400x600  
600x900



S DEC P

Cabin safety plan

**EMERGENCY INSTRUCTION NOTICE FOR PASSENGERS**

**YOUR ASSEMBLY STATION IS  
SU ESTACIÓN DE REUNIÓN SE HALLA EN**  **DECK 3  
PUENTE 3**

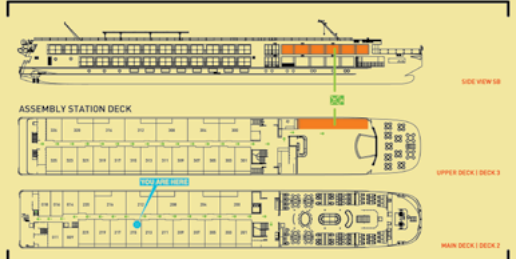

**ASSEMBLY STATION DECK**

**PRIMARY ESCAPE  
SALIDA PRINCIPAL**

**YOUR CABIN  
SU CABINA**

**SECONDARY ESCAPE  
SALIDA SECUNDARIA**

**GENERAL EMERGENCY ALARM SIGNAL**  
In the event of an Emergency the following signal will be sounded on the Ship's Whistle and on the Public Address System:  
**SEVEN (7) short blasts followed by one (1) long blast of the Ship's Whistle supplemented by the same signal over the Loudspeakers.**

**ACTION ON HEARING THE GENERAL EMERGENCY SIGNAL**  
On hearing the General Emergency Alarm Signal:  
1. Proceed directly to your Assembly Station if you are in a location remote from your cabin.  
2. If you are in your cabin or close to your cabin when the signal is heard, dress warmly, collect your Luggage and any wearable medication and follow the Direction Signs to your Assembly Station.  
3. Assist those who need help.  
4. Follow the instructions of Crew Members and those given over the Public Address System.  
5. DO NOT return to your cabin to collect your property.  
6. DO NOT use lifts and  
7. If the Primary Escape is blocked, use the Secondary Escape which is shown by a dotted arrow, as marked on the plan above.

**ASSEMBLY STATIONS**  
An Assembly Station is a space where passengers assemble when the General Alarm Signal has been sounded. The Assembly Stations of the ship are located on Deck 3.

**ACTIONS ON ARRIVAL AT THE ASSEMBLY STATION**  
Stay calm and follow the instructions of the Crew Members at your Assembly Station.  
- Put on your Luggage, if you do not have a Luggage Crew Members will obtain one for you.

**LOW LOCATION LIGHTING**  
In event of an Emergency, a Low Level Outdoors System will be activated. It consists of a Lighted Strip placed on the floor outside your cabin.  
Follow the Lighted Strip if it lead you to an Exit.  
If there is smoke in the corridor, keep close to the floor and crawl, if necessary, to avoid breathing the smoke, and to see more clearly.

**IF YOU SEE SMOKE OR SMALL BURNING**  
Inform the ship's personnel immediately.

**MAN OVERBOARD**  
If you see someone fall overboard throw a lifebuoy and inform immediately the ship's personnel.

**SEÑAL DE EMERGENCIA GENERAL**  
En caso de Emergencia la siguiente señal será producida por los Soneros del Buque y por los Altavoces:  
**SEVEN (7) short blasts followed by one (1) long blast of the Siren de Buque y repetida por los Altavoces.**

**ACCIONES DE SEGUIR AL OIR LA SEÑAL DE EMERGENCIA GENERAL**  
Al oír la Señal de Emergencia General:  
1. Si se encuentra en un lugar lejano de su camarote, diríjase directamente a la Estación de reunión correspondiente.  
2. Si se encuentra en su camarote o en un lugar cerca de este, cuando la señal sea transmitida, póngase ropa que mantenga el calor, tome su Chaqueta Salvavidas y cualquier medicación que le sea indispensable y siga las señales que le indiquen el camino para llegar a la Estación de reunión.  
3. Ayude a quien lo necesite.  
4. Siga las instrucciones de los Tripulantes y las instrucciones por los Altavoces.  
5. NO regrese a su camarote para recoger objetos personales.  
6. NO utilice los ascensores.  
7. Si la salida Principal se encuentra bloqueada, utilice la Salida Secundaria (marcada con una línea punteada).

**ESTACIÓN DE REUNIÓN (ASSEMBLY STATION)**  
Una Estación de Reunión es un punto en el cual los pasajeros se reúnen en caso de Emergencia. Las estaciones de reunión (Assembly Station) se encuentran en el Puente 3.

**ACCIONES DE SEGUIR CUANDO LLEGUE A SU ESTACIÓN DE REUNIÓN**  
Permanezca tranquilo y siga las instrucciones de los Tripulantes en la Estación de Reunión.  
- Póngase su Chaqueta Salvavidas, Si no tiene Chaqueta Salvavidas, pídale a un Miembro de la Tripulación.

**GUÍAS LUMINOSAS**  
En caso de Emergencia, se activará un sistema luminoso. Este sistema consiste en una cinta luminosa puesta en los pasillos sobre el suelo. Siga el sistema luminoso hasta llegar a una Salida. En caso de humo en los pasillos, cúbale la cabeza y, si es necesario, no más cerca posible del suelo, para evitar de inhalar el humo y para tener mejor visibilidad.

**EN CASO DE HUMO U OLORES DE QUEIMADO**  
Evite inmediatamente al personal del buque.

**HOMBRE AL AGUA**  
Si usted ve caer una persona en el agua lance inmediatamente un salvavidas y avise al personal del buque.



(mm)  
200x300



S CAB P



## Decorative and onboard way-finding signs

---

ⓈEverlux® has the ability to design, develop and manufacture way-finding and decorative signage solutions in different base materials, always with a high concern on the aesthetics of the signs and their most suitable integration with the general interior decoration of the vessel.

## Cabin identification

---



## Deck identification and cabin facility way-finding

---



For more information on this service, please contact us at: [commercial@everluxmaritime.com](mailto:commercial@everluxmaritime.com)

# □ Frame and Adhesive

## ⊗ Everlux® frames



Self-Assembly Frame S 80 01



Slim-Line Frame S 80 02

⊗ Everlux® frames are the ideal accessory when installing safety signs providing an aesthetic finish. They have a discreet and elegant design and are manufactured using high quality materials. They allow the connection between the sign and the wall and their visual weight does not conflict with the sign, resulting in a perfect harmony between the three elements (wall-frame-sign).

**Properties:**  
Material: Aluminium

**Available models:**  
⊗ Everlux® self-assembly frame – 4 aluminium components, cut to match the size of the sign are supplied along with 4 plastic “L” connectors and 4 squares of double-sided adhesive tape, to allow putting together this practical frame.

⊗ Everlux® slim-line frame – supplied with the respective sign and ready to be installed.

**Installation:**  
Both frames can be pasted to the wall by using double-sided adhesive tape or ⊗ Everlux® adhesive.  
Frames are only suitable to square and rectangular shaped signs.

## ⊗ Everlux® adhesive



Applied correctly  
⊗ Everlux® adhesive  
has been proven to be  
more cost effective  
than other adhesive  
brands

Adhesive (290ml) ADHE

Clean and fast application, is flexible with excellent mechanical properties indoor and outdoor. Free of solvents and silicone.

High adhesion to most surfaces, including irregular surfaces. Resistant to temperature variations and UV rays.

Signs and application surfaces must be clean and degreased. application must be done within + 5°C to + 40°C.

Apply a 5mm N-shaped adhesive wire on the back of the plate to cover the entire area. Press the sign against the installation surface. You can adjust the sign position within the first 5 minutes after the installation.

The service temperature is -40°C to + 90°C.

With a cord of 5mm in diameter and 15m linear: 29 signs (15x15cm), 19 signs (30x15cm), 12 signs (40x30 cm).

Apply the product in well ventilated areas. Contains: Bis(1,2,2,6,6-pentamethyl-4-piperidyl)sebacate, N-(3-(trimethoxysilyl) propyl)ethylenediamine. May cause allergic reaction. In case of contact with eyes, rinse with plenty of water.

Use a cloth moistened with alcohol to clean the surface of the sign and the installation surface. Store in a cool and dry place, with temperatures between + 5°C and +25°C.



# IMPA and ISSA cross reference guide

IMPA	ISSA	Everlux	Page	IMPA	ISSA	Everlux	Page	IMPA	ISSA	Everlux	Page	IMPA	ISSA	Everlux	Page
33.1501	47.515.01	S 60 56	73	33.1543	47.515.43	S 63 71	83	33.2221	47.522.21	S 55 34	69	33.2417	47.524.17	S 42 66	54
33.1502	47.515.02	S 60 53	73	33.1545	47.515.45	S 60 54	73	33.2222	47.522.22	S 55 02	69	33.2418	47.524.18	S 42 67	54
33.1503	47.515.03	S 60 55	73	33.1548	47.515.48	S 60 06	72	33.2223	47.522.23	S 55 03	69	33.2419	47.524.19	S 42 04	54
33.1504	47.515.04	S 60 57	74	33.1557	47.515.57	S 60 03	71	33.2224	47.522.24	S 55 04	69	33.2420	47.524.20	S 42 02	54
33.1505	47.515.05	S 60 58	74	33.1558	47.515.58	S 60 61	74	33.2225	47.522.25	S 55 05	69	33.2421	47.524.21	S 42 03	54
33.1506	47.515.06	S 63 07	79	33.1559	47.515.59	S 60 71	75	33.2230	47.522.30	S 56 61	70	33.2422	47.524.22	S 42 68	54
33.1507	47.515.07	S 63 09	80	33.1565	47.515.65	S 62 53	78	33.2231	47.522.31	S 56 01	69	33.2423	47.524.23	S 42 69	54
33.1508	47.515.08	S 63 01	78	33.1579	47.515.79	S 60 08	72	33.2232	47.522.32	S 56 06	69	33.2424	47.524.24	S 42 70	54
33.1509	47.515.09	S 63 18	81	33.2130	47.521.30	S 50 00	66	33.2233	47.522.33	S 56 03	69	33.2425	47.524.25	S 42 71	54
33.1510	47.515.10	S 62 52	78	33.2140	47.521.40	S 50 01	66	33.2234	47.522.34	S 56 05	69	33.2426	47.524.26	S 42 72	54
33.1511	47.515.11	S 62 51	78	33.2141	47.521.41	S 50 02	66	33.2235	47.522.35	S 56 51	70	33.2427	47.524.27	S 42 73	54
33.1512	47.515.12	S 62 54	78	33.2142	47.521.42	S 50 03	66	33.2236	47.522.36	S 56 52	70	33.2428	47.524.28	S 42 74	54
33.1513	47.515.13	S 62 03	77	33.2143	47.521.43	S 50 04	66	33.2237	47.522.37	S 56 53	70	33.2429	47.524.29	S 42 75	54
33.1514	47.515.14	S 62 04	77	33.2144	47.521.44	S 50 05	66	33.2238	47.522.38	S 56 55	70	33.2430	47.524.30	S 42 76	54
33.1515	47.515.15	S 60 52	72	33.2145	47.521.45	S 50 06	66	33.2277	47.522.77	S 56 56	70	33.2431	47.524.31	S 42 77	54
33.1516	47.515.16	S 60 51	72	33.2146	47.521.46	S 50 07	66	33.2240	47.522.40	S 56 57	70	33.2432	47.524.32	S 42 78	54
33.1517	47.515.17	S 63 08	79	33.2147	47.521.47	S 50 08	66	33.2241	47.522.41	S 56 58	70	33.2433	47.524.33	S 42 79	54
33.1520	47.515.20	S 60 59	74	33.2148	47.521.48	S 50 09	66	33.2242	47.522.42	S 56 59	70	33.2434	47.524.34	S 42 80	54
33.1521	47.515.21	S 62 05	77	33.2149	47.521.49	S 50 10	66	33.2243	47.522.43	S 56 60	70	33.2435	47.524.35	S 42 81	54
33.1522	47.515.22	S 63 13	80	33.2150	47.521.50	S 50 11	66	33.2251	47.522.51	S 55 12	69	33.2436	47.524.36	S 42 82	54
33.1523	47.515.23	S 63 02	78	33.2151	47.521.51	S 50 12	66	33.2253	47.522.53	S 55 32	69	33.2437	47.524.37	S 42 83	54
33.1524	47.515.24	S 63 03	79	33.2201	47.522.01	S 59 01	70	33.2401	47.524.01	S 42 51	54	33.2438	47.524.38	S 42 84	54
33.1525	47.515.25	S 63 12	80	33.2202	47.522.02	S 55 19	69	33.2402	47.524.02	S 42 52	54	33.2439	47.524.39	S 42 85	54
33.1526	47.515.26	S 62 00	76	33.2207	47.522.07	S 55 14	69	33.2403	47.524.03	S 42 53	54	33.2440	47.524.40	S 42 86	54
33.1527	47.515.27	S 60 01	71	33.2208	47.522.08	S 55 16	69	33.2404	47.524.04	S 42 54	54	33.2441	47.524.41	S 42 87	54
33.1528	47.515.28	S 63 05	79	33.2209	47.522.09	S 55 18	69	33.2405	47.524.05	S 42 55	54	33.2442	47.524.42	S 42 88	54
33.1529	47.515.29	S 63 22	83	33.2210	47.522.10	S 55 21	69	33.2406	47.524.06	S 42 56	54	33.2443	47.524.43	S 42 89	54
33.1530	47.515.30	S 63 11	80	33.2211	47.522.11	S 55 22	69	33.2407	47.524.07	S 42 57	54	33.2501	47.525.01	S 47 01	64
33.1531	47.515.31	S 63 14	80	33.2212	47.522.12	S 55 23	69	33.2408	47.524.08	S 42 58	54	33.2502	47.525.02	S 47 02	64
33.1532	47.515.32	S 63 15	81	33.2213	47.522.13	S 55 25	69	33.2409	47.524.09	S 42 59	54	33.2503	47.525.03	S 47 03	64
33.1533	47.515.33	S 63 04	79	33.2275	47.522.75	S 55 26	69	33.2410	47.524.10	S 42 60	54	33.2504	47.525.04	S 47 04	64
33.1534	47.515.34	S 62 02	77	33.2215	47.522.15	S 55 27	69	33.2411	47.524.11	S 42 61	54	33.2506	47.525.06	S 47 05	64
33.1536	47.515.36	S 60 02	71	33.2216	47.522.16	S 55 28	69	33.2412	47.524.12	S 42 62	54	33.2507	47.525.07	S 47 06	64
33.1537	47.515.37	S 63 62	83	33.2217	47.522.17	S 55 29	69	33.2413	47.524.13	S 42 01	54	33.2508	47.525.08	S 47 07	64
33.1539	47.515.39	S 63 64	83	33.2218	47.522.18	S 55 30	69	33.2414	47.524.14	S 42 63	54	33.2509	47.525.09	S 47 08	64
33.1541	47.515.41	S 63 63	83	33.2219	47.522.19	S 55 31	69	33.2415	47.524.15	S 42 64	54	33.2510	47.525.10	S 47 09	64
33.1542	47.515.42	S 63 21	82	33.2220	47.522.20	S 55 33	69	33.2416	47.524.16	S 42 65	54	33.2520	47.525.20	S 47 55	64

1) Sign with the same message as IMPA and ISSA sign, but with a different format

# IMPA and ISSA cross reference guide

IMPA	ISSA	Everlux	Page	IMPA	ISSA	Everlux	Page	IMPA	ISSA	Everlux	Page	IMPA	ISSA	Everlux	Page
33.2521	47.525.21	S 47 54	64	33.3123	47.531.23	S 41 02	53	33.4080	47.540.80	S 02 14	10	33.4139	47.541.39	S 03 11	12
33.2522	47.525.22	S 47 53	64	33.3124	47.531.24	S 41 03	53	33.4100	47.541.00	S 02 51	11	33.4140	47.541.40	S 03 40	12
33.2523	47.525.23	S 47 52	64	33.3125	47.531.25	S 41 05	53	33.4101	47.541.01	S 02 52	11	33.4142	47.541.42	S 02 64	11
33.2524	47.525.24	S 47 51	64	33.3126	47.531.26	S 41 06	53	33.4102	47.541.02	S 02 53	11	33.4145	47.541.45	S 03 04	12
33.2525	47.525.25	S 47 56	64	33.3127	47.531.27	S 41 08	53	33.4103	47.541.03	S 02 54	11	33.4150	47.541.50	S 02 26	10
33.2526	47.525.26	S 47 57	64	33.3128	47.531.28	S 41 09	53	33.4104	47.541.04	S 02 55	11	33.4152	47.541.52	S 03 03	12
33.2527	47.525.27	S 47 59	64	33.3129	47.531.29	S 41 10	53	33.4105	47.541.05	S 02 56	11	33.4153	47.541.53	S 02 28	10
33.2528	47.525.28	S 47 58	64	33.3135	47.531.35	S 41 11	53	33.4106	47.541.06	S 02 57	11	33.4154	47.541.54	S 03 14	12
33.2529	47.525.29	S 47 60	64	33.3136	47.531.36	S 41 12	53	33.4107	47.541.07	S 02 58	11	33.4155	47.541.55	S 03 13	12
33.2530	47.525.30	S 47 61	64	33.3137	47.531.37	S 41 13	53	33.4108	47.541.08	S 02 59	11	33.4170	47.541.70	S 03 21	12 <sup>1</sup>
33.2531	47.525.31	S 47 62	64	33.3138	47.531.38	S 40 72	52	33.4109	47.541.09	S 02 60	11	33.4171	47.541.71	S 03 38	12
33.2532	47.525.32	S 47 63	64	33.3139	47.531.39	S 40 73	52	33.4110	47.541.10	S 02 62	11	33.4172	47.541.72	S 03 34	12
33.2540	47.525.40	S 47 81	64	33.4050	47.540.50	S 02 01	10	33.4111	47.541.11	S 02 63	11	33.4173	47.541.73	S 03 39	12
33.2541	47.525.41	S 47 10	64	33.4051	47.540.51	S 02 02	10	33.4112	47.541.12	S 02 65	11	33.4174	47.541.74	S 03 49	12
33.2542	47.525.42	S 47 11	64	33.4052	47.540.52	S 02 03	10	33.4113	47.541.13	S 02 73	11	33.4175	47.541.75	S 03 50	12
33.2703	47.527.03	S 42 10	55 <sup>1</sup>	33.4053	47.540.53	S 02 04	10	33.4114	47.541.14	S 02 69	11	33.4176	47.541.76	S 03 33	12
33.2889	47.528.89	S 42 42	56	33.4054	47.540.54	S 02 05	10	33.4115	47.541.15	S 02 70	11	33.4177	47.541.77	S 03 32	12
33.2896	47.528.96	S 42 40	56	33.4055	47.540.55	S 02 06	10	33.4116	47.541.16	S 02 68	11	33.4178	47.541.78	S 03 45	12
33.2974	47.529.74	S 42 41	56	33.4056	47.540.56	S 02 07	10	33.4117	47.541.17	S 02 71	11	33.4179	47.541.79	S 03 42	12
33.3014	47.530.14	S 40 71	52	33.4057	47.540.57	S 02 08	10	33.4118	47.541.18	S 02 72	11	33.4180	47.541.80	S 03 44	12
33.3100	47.531.00	S 40 51	52	33.4058	47.540.58	S 02 09	10	33.4119	47.541.19	S 03 62	13	33.4181	47.541.81	S 03 53	12
33.3101	47.531.01	S 40 52	52	33.4059	47.540.59	S 02 10	10	33.4120	47.541.20	S 02 74	11	33.4182	47.541.82	S 03 48	12
33.3102	47.531.02	S 40 53	52	33.4060	47.540.60	S 02 12	10	33.4121	47.541.21	S 02 75	11	33.4183	47.541.83	S 03 51	12
33.3103	47.531.03	S 40 54	52	33.4061	47.540.61	S 02 13	10	33.4123	47.541.23	S 02 51	11	33.4184	47.541.84	S 03 52	12
33.3104	47.531.04	S 40 58	52	33.4062	47.540.62	S 02 15	10	33.4124	47.541.24	S 03 62	13	33.4187	47.541.87	S 05 51	16
33.3105	47.531.05	S 40 59	52	33.4063	47.540.63	S 02 23	10	33.4125	47.541.25	S 02 66	11	33.4188	47.541.88	S 03 43	12
33.3106	47.531.06	S 40 60	52	33.4064	47.540.64	S 02 19	10	33.4126	47.541.26	S 02 67	11	33.4189	47.541.89	S 03 47	12
33.3108	47.531.08	S 40 81	53	33.4065	47.540.65	S 02 20	10	33.4127	47.541.27	S 02 76	11	33.4200	47.542.00	S 04 00	14
33.3109	47.531.09	S 40 55	52	33.4066	47.540.66	S 02 18	10	33.4129	47.541.29	S 02 77	11	33.4201	47.542.01	S 04 01	14
33.3110	47.531.10	S 40 61	52	33.4067	47.540.67	S 02 21	10	33.4130	47.541.30	S 03 46	12 <sup>1</sup>	33.4202	47.542.02	S 04 02	14
33.3111	47.531.11	S 41 04	53	33.4068	47.540.68	S 02 22	10	33.4131	47.541.31	S 02 78	11	33.4203	47.542.03	S 04 03	14
33.3112	47.531.12	S 40 56	52	33.4069	47.540.69	S 03 61	13	33.4132	47.541.32	S 02 84	11	33.4204	47.542.04	S 04 04	14
33.3113	47.531.13	S 40 62	52	33.4070	47.540.70	S 02 24	10	33.4134	47.541.34	S 02 61	11	33.4205	47.542.05	S 04 05	14
33.3114	47.531.14	S 40 63	52	33.4071	47.540.71	S 02 25	10	33.4135	47.541.35	S 03 10	12	33.4206	47.542.06	S 04 06	14
33.3115	47.531.15	S 40 64	52	33.4075	47.540.75	S 02 16	10	33.4136	47.541.36	S 03 37	12	33.4207	47.542.07	S 04 07	14
33.3116	47.531.16	S 40 57	52	33.4076	47.540.76	S 02 17	10	33.4137	47.541.37	S 03 02	12	33.4208	47.542.08	S 04 08	14
33.3122	47.531.22	S 41 01	53	33.4078	47.540.78	S 02 27	10	33.4138	47.541.38	S 03 31	12	33.4209	47.542.09	S 04 09	14

1) Sign with the same message as IMPA and ISSA sign, but with a different format

# IMPA and ISSA cross reference guide

IMPA	ISSA	Everlux	Page	IMPA	ISSA	Everlux	Page	IMPA	ISSA	Everlux	Page	IMPA	ISSA	Everlux	Page
33.4210	47.542.10	S 04 1A	14	33.4325	47.543.25	S 03 79	13	33.4424	47.544.24	S 04 65	15	33.5653	47.556.53	S 35 11	44
33.4211	47.542.11	S 04 1B	14	33.4326	47.543.26	S 03 83	13	33.4425	47.544.25	S 04 63	15	33.5654	47.556.54	S 35 08	44
33.4212	47.542.12	S 04 1C	14	33.4327	47.543.27	S 03 80	13	33.4426	47.544.26	S 04 10	14 <sup>1</sup>	33.5655	47.556.55	S 35 21	44
33.4213	47.542.13	S 04 1D	14	33.4328	47.543.28	S 03 82	13	33.4427	47.544.27	S 04 10	14	33.5656	47.556.56	S 00 11	9
33.4214	47.542.14	S 04 1E	14	33.4329	47.543.29	S 03 81	13	33.4454	47.544.54	S 03 66	15	33.5675	47.556.75	S 35 91	46
33.4215	47.542.15	S 04 1F	14	33.4331	47.543.31	S 03 77	13	33.4455	47.544.55	S 03 67	15	33.5678	47.556.78	S 35 69	45
33.4240	47.542.40	S 04 00	14	33.4332	47.543.32	S 03 76	13	33.4470	47.544.70	S 04 15	14	33.5679	47.556.79	S 36 16	46
33.4241	47.542.41	S 04 01	14	33.4333	47.543.33	S 03 78	13	33.4471	47.544.71	S 04 16	14	33.5680	47.556.80	S 36 84	47
33.4242	47.542.42	S 04 02	14	33.4334	47.543.34	S 03 75	13	33.4480	47.544.80	S 05 18	16	33.5690	47.556.90	S 36 48	47
33.4243	47.542.43	S 04 03	14	33.4335	47.543.35	S 03 71	13	33.4481	47.544.81	S 05 19	16	33.5691	47.556.91	S 36 49	47
33.4244	47.542.44	S 04 04	14	33.4336	47.543.36	S 03 74	13	33.4482	47.544.82	S 05 15	16	33.5692	47.556.92	S 36 50	47
33.4245	47.542.45	S 04 05	14	33.4337	47.543.37	S 03 72	13	33.4483	47.544.83	S 05 16	16	33.5693	47.556.93	S 36 52	47
33.4246	47.542.46	S 04 06	14	33.4339	47.543.39	S 03 73	15	33.4820	47.548.20	S 04 71	15	33.5694	47.556.94	S 36 53	47
33.4247	47.542.47	S 04 07	14	33.4340	47.543.40	S 04 55	14	33.4821	47.548.21	S 04 93	15	33.5695	47.556.95	S 36 54	47
33.4248	47.542.48	S 04 08	14	33.4345	47.543.45	S 04 51	15	33.4824	47.548.24	S 04 85	15	33.5709	47.557.09	S 35 67	45
33.4249	47.542.49	S 04 09	14	33.4342	47.543.42	S 04 54	15	33.4825	47.548.25	S 04 81	15	33.5710	47.557.10	S 35 51	45 <sup>1</sup>
33.4250	47.542.50	S 04 1A	14	33.4343	47.543.43	S 04 52	15	33.5100	47.551.00	S 01 01	9	33.5712	47.557.12	S 35 53	45 <sup>1</sup>
33.4251	47.542.51	S 04 1B	14	33.4344	47.543.44	S 04 53	15	33.5101	47.551.01	S 01 02	9	33.5716	47.557.16	S 35 73	45 <sup>1</sup>
33.4252	47.542.52	S 04 1C	14	33.4341	47.543.41	S 04 56	15	33.5102	47.551.02	S 01 03	9	33.5719	47.557.19	S 35 68	45
33.4253	47.542.53	S 04 1D	14	33.4400	47.544.00	S 04 42	15	33.5103	47.551.03	S 01 04	9	33.5721	47.557.21	S 35 60	45 <sup>1</sup>
33.4254	47.542.54	S 04 1E	14	33.4401	47.544.01	S 04 43	15	33.5104	47.551.04	S 01 05	9	33.5722	47.557.22	S 35 61	45 <sup>1</sup>
33.4255	47.542.55	S 04 1F	14	33.4402	47.544.02	S 04 41	15	33.5105	47.551.05	S 01 06	9	33.5723	47.557.23	S 35 55	45 <sup>1</sup>
33.4300	47.543.00	S 03 96	13	33.4403	47.544.03	S 04 44	15	33.5106	47.551.06	S 01 07	9	33.5724	47.557.24	S 35 65	45 <sup>1</sup>
33.4301	47.543.01	S 03 97	13	33.4404	47.544.04	S 04 40	15	33.5107	47.551.07	S 01 08	9	33.5725	47.557.25	S 35 70	45
33.4302	47.543.02	S 03 95	13	33.4405	47.544.05	S 04 35	15	33.5108	47.551.08	S 01 09	9	33.5726	47.557.26	S 35 76	45 <sup>1</sup>
33.4303	47.543.03	S 03 98	13	33.4406	47.544.06	S 04 39	15	33.5109	47.551.09	S 01 10	9	33.5727	47.557.27	S 35 66	45 <sup>1</sup>
33.4304	47.543.04	S 03 94	13	33.4407	47.544.07	S 04 36	15	33.5642	47.556.42	S 35 01	44	33.5728	47.557.28	S 35 71	45 <sup>1</sup>
33.4305	47.543.05	S 03 89	13	33.4408	47.544.08	S 04 38	15	33.5643	47.556.43	S 35 24	44	33.5729	47.557.29	S 35 92	46 <sup>1</sup>
33.4306	47.543.06	S 03 93	13	33.4409	47.544.09	S 04 37	15	33.5644	47.556.44	S 35 02	44	33.5731	47.557.31	S 35 64	45 <sup>1</sup>
33.4307	47.543.07	S 03 90	13	33.4410	47.544.10	S 04 46	15	33.5645	47.556.45	S 35 12	44	33.5733	47.557.33	S 35 52	45 <sup>1</sup>
33.4308	47.543.08	S 03 92	13	33.4411	47.544.11	S 04 45	15	33.5646	47.556.46	S 35 05	44	33.5734	47.557.34	S 35 54	45 <sup>1</sup>
33.4309	47.543.09	S 03 91	13	33.4413	47.544.13	S 04 47	15	33.5647	47.556.47	S 35 04	44	33.5735	47.557.35	S 35 91	46
33.4320	47.543.20	S 03 86	13	33.4416	47.544.16	S 04 48	15	33.5648	47.556.48	S 35 03	44	33.5736	47.557.36	S 36 46	47 <sup>1</sup>
33.4321	47.543.21	S 03 87	13	33.4420	47.544.20	S 03 64	13	33.5649	47.556.49	S 35 06	44	33.5737	47.557.37	S 36 42	47 <sup>1</sup>
33.4322	47.543.22	S 03 85	13	33.4421	47.544.21	S 03 65	13	33.5650	47.556.50	S 35 07	44	33.5738	47.557.38	S 36 43	47 <sup>1</sup>
33.4323	47.543.23	S 03 88	13	33.4422	47.544.22	S 04 61	15	33.5651	47.556.51	S 35 15	44	33.5739	47.557.39	S 36 44	47 <sup>1</sup>
33.4324	47.543.24	S 03 84	13	33.4423	47.544.23	S 04 62	15	33.5652	47.556.52	S 35 14	44	33.5740	47.557.40	S 36 45	47 <sup>1</sup>

1) Sign with the same message as IMPA and ISSA sign, but with a different format

# IMPA and ISSA cross reference guide

IMPA	ISSA	Everlux	Page	IMPA	ISSA	Everlux	Page	IMPA	ISSA	Everlux	Page	IMPA	ISSA	Everlux	Page
33.5745	47.557.45	S 36 55	47	33.5878	47.558.78	S 36 82	47 <sup>1</sup>	33.6033	47.560.33	S 10 71	18	33.6070	47.560.70	S 10 56	18
33.5746	47.557.46	S 36 56	47	33.5900	47.559.00	S 61 04	75	33.6034	47.560.34	S 10 70	18	33.6071	47.560.71	S 10 57	18
33.5768	47.557.68	S 36 47	47 <sup>1</sup>	33.5901	47.559.01	S 61 05	75	33.6035	47.560.35	S 10 72	18	33.6072	47.560.72	S 10 77	19
33.5769	47.557.69	S 36 83	47 <sup>1</sup>	33.5902	47.559.02	S 61 03	75	33.6036	47.560.36	S 10 64	18	33.6073	47.560.73	S 10 65	18
33.5782	47.557.82	S 35 77	45 <sup>1</sup>	33.5903	47.559.03	S 61 06	75	33.6037	47.560.37	S 10 60	18	33.6074	47.560.74	S 10 66	18
33.5800	47.558.00	S 34 21	43	33.6001	47.560.01	S 10 01	17	33.6038	47.560.38	S 10 73	18	33.6075	47.560.75	S 10 67	18
33.5801	47.558.01	S 34 31	43	33.6002	47.560.02	S 10 02	17	33.6039	47.560.39	S 10 75	19	33.6076	47.560.76	S 10 68	18
33.5802	47.558.02	S 34 20	43	33.6003	47.560.03	S 10 03	17	33.6040	47.560.40	S 10 74	18	33.6077	47.560.77	S 10 78	19
33.5803	47.558.03	S 34 08	43	33.6004	47.560.04	S 10 04	17	33.6041	47.560.41	S 10 76	19	33.6078	47.560.78	S 10 79	19
33.5804	47.558.04	S 34 07	43	33.6005	47.560.05	S 10 05	17	33.6042	47.560.42	S 10 80	19	33.6079	47.560.79	S 10 43	18
33.5805	47.558.05	S 34 09	43	33.6006	47.560.06	S 10 06	17	33.6043	47.560.43	S 10 07	17	33.6080	47.560.80	S 10 44	18
33.5806	47.558.06	S 34 35	43	33.6007	47.560.07	S 10 13	17	33.6044	47.560.44	S 10 08	17	33.6081	47.560.81	S 10 45	18
33.5807	47.558.07	S 34 13	43	33.6008	47.560.08	S 10 14	17	33.6045	47.560.45	S 10 09	17	33.6082	47.560.82	S 10 46	18
33.5808	47.558.08	S 34 02	43	33.6009	47.560.09	S 10 15	17	33.6046	47.560.46	S 10 11	17	33.6083	47.560.83	S 10 47	18
33.5809	47.558.09	S 34 29	43	33.6010	47.560.10	S 10 16	17	33.6047	47.560.47	S 10 10	17	33.6084	47.560.84	S 10 48	18
33.5811	47.558.11	S 34 15	43	33.6011	47.560.11	S 10 17	17	33.6048	47.560.48	S 10 12	17	33.6085	47.560.85	S 10 49	18
33.5812	47.558.12	S 34 18	43	33.6012	47.560.12	S 10 18	17	33.6049	47.560.49	S 10 19	17	33.6086	47.560.86	S 10 50	18
33.5814	47.558.14	S 34 14	43	33.6013	47.560.13	S 10 25	17	33.6050	47.560.50	S 10 20	17	33.6087	47.560.87	S 14 55	23
33.5817	47.558.17	S 34 01	43	33.6014	47.560.14	S 10 26	17	33.6051	47.560.51	S 10 21	17	33.6088	47.560.88	S 14 58	23
33.5818	47.538.18	S 34 04	43	33.6015	47.560.15	S 10 27	17	33.6052	47.560.52	S 10 22	17	33.6089	47.560.89	S 14 57	23
33.5819	47.538.19	S 34 05	43	33.6016	47.560.16	S 10 28	17	33.6053	47.560.53	S 10 23	17	33.6091	47.560.91	S 14 56	23
33.5820	47.538.20	S 34 06	43	33.6017	47.560.17	S 10 29	17	33.6054	47.560.54	S 10 24	17	33.6100	47.561.00	S 16 01	24
33.5822	47.558.22	S 34 38	43	33.6018	47.560.18	S 10 30	17	33.6055	47.560.55	S 10 84	19	33.6101	47.561.01	S 13 12	22
33.5824	47.558.24	S 36 01	46	33.6019	47.560.19	S 10 34	18	33.6056	47.560.56	S 10 81	19	33.6102	47.561.02	S 16 06	24
33.5825	47.558.25	S 36 03	46	33.6020	47.560.20	S 10 35	18	33.6057	47.560.57	S 10 41	18	33.6103	47.561.03	S 18 05	27
33.5851	47.558.51	S 36 17	46	33.6021	47.560.21	S 10 36	18	33.6058	47.560.58	S 10 31	17	33.6104	47.561.04	S 18 06	27
33.5852	47.558.52	S 36 18	46	33.6022	47.560.22	S 10 37	18	33.6059	47.560.59	S 10 32	17	33.6120	47.561.20	S 16 72	25
33.5853	47.558.53	S 36 19	46	33.6023	47.560.23	S 10 38	18	33.6060	47.560.60	S 10 33	18	33.6121	47.561.21	S 18 23	27
33.5855	47.558.55	S 36 02	46	33.6024	47.560.24	S 10 39	18	33.6061	47.560.61	S 10 82	19	33.6122	47.561.22	S 16 75	25
33.5870	47.558.70	S 36 07	46 <sup>1</sup>	33.6025	47.560.25	S 10 85	19	33.6062	47.560.62	S 10 83	19	33.6123	47.561.23	S 18 21	27
33.5871	47.558.71	S 36 08	46 <sup>1</sup>	33.6026	47.560.26	S 10 86	19	33.6063	47.560.63	S 10 51	18	33.6124	47.561.24	S 18 22	27
33.5872	47.558.72	S 36 20	46 <sup>1</sup>	33.6027	47.560.27	S 10 40	18	33.6064	47.560.64	S 10 61	18	33.6140	47.561.40	S 19 01	28
33.5873	47.558.73	S 36 13	46 <sup>1</sup>	33.6028	47.560.28	S 10 58	18	33.6065	47.560.65	S 10 62	18	33.6141	47.561.41	S 19 10	28
33.5874	47.558.74	S 36 14	46 <sup>1</sup>	33.6029	47.560.29	S 10 42	18	33.6066	47.560.66	S 10 63	18	33.6142	47.561.42	S 19 11	28
33.5875	47.558.75	S 36 21	46 <sup>1</sup>	33.6030	47.560.30	S 10 52	18	33.6067	47.560.67	S 10 53	18	33.6143	47.561.43	S 19 12	28
33.5876	47.558.76	S 36 11	46 <sup>1</sup>	33.6031	47.560.31	S 10 59	18	33.6068	47.560.68	S 10 54	18	33.6144	47.561.44	S 19 06	28
33.5877	47.558.77	S 36 81	47 <sup>1</sup>	33.6032	47.560.32	S 10 69	18	33.6069	47.560.69	S 10 55	18	33.6145	47.561.45	S 19 07	28

1) Sign with the same message as IMPA and ISSA sign, but with a different format

# IMPA and ISSA cross reference guide

IMPA	ISSA	Everlux	Page	IMPA	ISSA	Everlux	Page	IMPA	ISSA	Everlux	Page	IMPA	ISSA	Everlux	Page
33.6146	47.561.46	S 19 09	28	33.6759	47.567.59	S 12 09	19	33.6797	47.567.97	S 12 47	20	33.6838	47.568.38	S 12 88	21
33.6147	47.561.47	S 19 13	28	33.6760	47.567.60	S 12 10	19	33.6799	47.567.99	S 12 49	20	33.6841	47.568.41	S 12 91	21
33.6149	47.561.49	S 19 23	28	33.6761	47.567.61	S 12 11	19	33.6801	47.568.01	S 12 51	20	33.6842	47.568.42	S 12 92	21
33.6150	47.561.50	S 19 34	28	33.6762	47.567.62	S 12 12	19	33.6802	47.568.02	S 12 52	20	33.6843	47.568.43	S 12 93	21
33.6151	47.561.51	S 19 24	28	33.6763	47.567.63	S 12 13	19	33.6803	47.568.03	S 12 53	20	33.6844	47.568.44	S 12 94	21
33.6152	47.561.52	S 19 18	28	33.6764	47.567.64	S 12 14	19	33.6804	47.568.04	S 12 54	20	33.6845	47.568.45	S 12 95	21
33.6153	47.561.53	S 19 19	28	33.6765	47.567.65	S 12 15	19	33.6805	47.568.05	S 12 55	20	33.6846	47.568.46	S 12 96	21
33.6154	47.561.54	S 19 20	28	33.6766	47.567.66	S 12 16	19	33.6806	47.568.06	S 12 56	20	33.6847	47.568.47	S 13 82	23
33.6155	47.561.55	S 19 21	28	33.6767	47.567.67	S 12 17	19	33.6807	47.568.07	S 12 57	20	33.6849	47.568.49	S 13 83	23
33.6157	47.561.57	S 19 29	28	33.6768	47.567.68	S 12 18	19	33.6808	47.568.08	S 12 58	20	33.6854	47.568.54	S 13 84	23
33.6158	47.561.58	S 19 22	28	33.6769	47.567.69	S 12 19	19	33.6809	47.568.09	S 12 59	20	33.6848	47.568.48	S 13 85	23
33.6159	47.561.59	S 19 28	28	33.6770	47.567.70	S 12 20	19	33.6810	47.568.10	S 12 61	20	33.6853	47.568.53	S 13 86	23
33.6160	47.561.60	S 19 26	28	33.6771	47.567.71	S 12 21	19	33.6812	47.568.12	S 12 62	20	33.6850	47.568.50	S 13 87	23
33.6163	47.561.63	S 19 03	28	33.6772	47.567.72	S 12 22	19	33.6813	47.568.13	S 12 63	21	33.6855	47.568.55	S 13 88	23
33.6164	47.561.64	S 19 05	28	33.6773	47.567.73	S 12 23	19	33.6815	47.568.15	S 12 65	21	33.6851	47.568.51	S 13 89	23
33.6165	47.561.65	S 19 04	28	33.6774	47.567.74	S 12 24	19	33.6816	47.568.16	S 12 69	21	33.6856	47.568.56	S 13 90	23
33.6210	47.562.10	S 16 10	24	33.6775	47.567.75	S 12 25	19	33.6817	47.568.17	S 12 68	21	33.6857	47.568.57	S 12 97	21
33.6211	47.562.11	S 16 09	24	33.6776	47.567.76	S 12 26	19	33.6818	47.568.18	S 12 66	21	33.6858	47.568.58	S 12 98	21
33.6300	47.563.00	S 18 48	27	33.6777	47.567.77	S 12 27	20	33.6819	47.568.19	S 12 67	21	33.6865	47.568.65	S 13 05	22
33.6301	47.563.01	S 16 85	24	33.6778	47.567.78	S 12 28	20	33.6820	47.568.20	S 12 70	21	33.6867	47.568.67	S 13 07	22
33.6500	47.565.00	S 25 71	38	33.6779	47.567.79	S 12 29	20	33.6821	47.568.21	S 12 71	21	33.6869	47.568.69	S 13 09	22
33.6501	47.565.01	S 25 11	38	33.6780	47.567.80	S 12 30	20	33.6822	47.568.22	S 12 73	21	33.6043	47.560.43	S 13 10	22
33.6502	47.565.02	S 25 73	38	33.6781	47.567.81	S 12 31	20	33.6823	47.568.23	S 12 72	21	33.6056	47.560.56	S 13 13	22
33.6503	47.565.03	S 25 17	38	33.6782	47.567.82	S 12 32	20	33.6824	47.568.24	S 12 74	21	33.6872	47.568.72	S 13 12	22
33.6504	47.565.04	S 25 72	38	33.6783	47.567.83	S 12 33	20	33.6825	47.568.25	S 12 75	21	33.6875	47.568.75	S 13 15	22
33.6505	47.565.05	S 25 15	38	33.6784	47.567.84	S 12 34	20	33.6826	47.568.26	S 12 76	21	33.7000	47.570.00	S 32 71	42
33.6506	47.565.06	S 25 74	38	33.6785	47.567.85	S 12 35	20	33.6827	47.568.27	S 12 77	21	33.7500	47.575.00	S 30 01	40 <sup>1</sup>
33.6507	47.565.07	S 25 19	38	33.6786	47.567.86	S 12 36	20	33.6828	47.568.28	S 12 79	21	33.7501	47.575.01	S 30 06	40 <sup>1</sup>
33.6715	47.567.15	S 14 51	23	33.6787	47.567.87	S 12 37	20	33.6829	47.568.29	S 12 78	21	33.7502	47.575.02	S 30 12	40 <sup>1</sup>
33.6751	47.567.51	S 12 01	19	33.6788	47.567.88	S 12 38	20	33.6830	47.568.30	S 12 80	21	33.7503	47.575.03	S 30 09	40 <sup>1</sup>
33.6752	47.567.52	S 12 02	19	33.6789	47.567.89	S 12 39	20	33.6831	47.568.31	S 12 81	21	33.7504	47.575.04	S 30 03	40 <sup>1</sup>
33.6753	47.567.53	S 12 03	19	33.6790	47.567.90	S 12 40	20	33.6832	47.568.32	S 12 82	21	33.7505	47.575.05	S 31 04	41 <sup>1</sup>
33.6754	47.567.54	S 12 04	19	33.6791	47.567.91	S 12 41	20	33.6833	47.568.33	S 12 83	21	33.7506	47.575.06	S 31 03	41 <sup>1</sup>
33.6755	47.567.55	S 12 05	19	33.6792	47.567.92	S 12 42	20	33.6834	47.568.34	S 12 85	21	33.7507	47.575.07	S 31 01	41 <sup>1</sup>
33.6756	47.567.56	S 12 06	19	33.6793	47.567.93	S 12 43	20	33.6835	47.568.35	S 12 84	21	33.7508	47.575.08	S 30 07	40 <sup>1</sup>
33.6757	47.567.57	S 12 07	19	33.6794	47.567.94	S 12 44	20	33.6836	47.568.36	S 12 86	21	33.7509	47.575.09	S 31 02	41 <sup>1</sup>
33.6758	47.567.58	S 12 08	19	33.6795	47.567.95	S 12 45	20	33.6837	47.568.37	S 12 87	21	33.7510	47.575.10	S 31 07	41 <sup>1</sup>

1) Sign with the same message as IMPA and ISSA sign, but with a different format

# IMPA and ISSA cross reference guide

IMPA	ISSA	Everlux	Page	IMPA	ISSA	Everlux	Page	IMPA	ISSA	Everlux	Page	IMPA	ISSA	Everlux	Page
33.7511	47.575.11	S 31 10	41 <sup>1</sup>	33.7584	47.575.84	S 30 77	40 <sup>1</sup>	33.7636	47.576.36	S 31 71	41 <sup>1</sup>	33.8544	47.585.44	S 38 66	49
33.7515	47.575.15	S 31 12	41 <sup>1</sup>	33.7585	47.575.85	S 30 78	40 <sup>1</sup>	33.7650	47.576.50	S 31 81	42 <sup>1</sup>	33.8545	47.585.45	S 38 64	49
33.7516	47.575.16	S 30 02	40 <sup>1</sup>	33.7587	47.575.87	S 31 54	41 <sup>1</sup>	33.7651	47.576.51	S 32 00	42 <sup>1</sup>	33.8546	47.585.46	S 38 65	49
33.7540	47.575.40	S 30 51	40 <sup>1</sup>	33.7590	47.575.90	S 31 77	41 <sup>1</sup>	33.7660	47.576.60	S 31 82	42 <sup>1</sup>	33.8547	47.585.47	S 39 95	51
33.7541	47.575.41	S 32 15	42 <sup>1</sup>	33.7591	47.575.91	S 31 78	41 <sup>1</sup>	33.7668	47.576.68	S 30 72	40 <sup>1</sup>	33.8548	47.585.48	S 38 70	49
33.7542	47.575.42	S 30 52	40 <sup>1</sup>	33.7596	47.575.96	S 31 79	41 <sup>1</sup>	33.7670	47.576.70	S 31 83	42 <sup>1</sup>	33.8549	47.585.49	S 38 63	49
33.7543	47.575.43	S 30 53	40 <sup>1</sup>	33.7597	47.575.97	S 31 80	41 <sup>1</sup>	33.7673	47.576.73	S 31 86	42 <sup>1</sup>	33.8550	47.585.50	S 39 52	50
33.7544	47.575.44	S 30 54	40 <sup>1</sup>	33.7598	47.575.98	S 32 58	42	33.7680	47.576.80	S 31 84	42 <sup>1</sup>	33.8550	47.585.50	S 40 17	51
33.7545	47.575.45	S 30 55	40 <sup>1</sup>	33.7600	47.576.00	S 31 72	41 <sup>1</sup>	33.7681	47.576.81	S 31 85	42 <sup>1</sup>	33.8551	47.585.51	S 39 58	50
33.7546	47.575.46	S 30 56	40 <sup>1</sup>	33.7601	47.576.01	S 31 73	41 <sup>1</sup>	33.7700	47.577.00	S 32 12	42	33.8552	47.585.52	S 39 57	50
33.7547	47.575.47	S 30 57	40 <sup>1</sup>	33.7604	47.576.04	S 31 74	41 <sup>1</sup>	33.7701	47.577.01	S 32 13	42	33.8553	47.585.53	S 38 71	49
33.7548	47.575.48	S 30 58	40 <sup>1</sup>	33.7605	47.576.05	S 31 75	41 <sup>1</sup>	33.8000	47.580.00	S 32 61	42	33.8555	47.585.55	S 39 60	50
33.7549	47.575.49	S 30 61	40 <sup>1</sup>	33.7610	47.576.10	S 31 51	41 <sup>1</sup>	33.8500	47.585.00	S 38 01	48	33.8556	47.585.56	S 39 67	50
33.7550	47.575.50	S 30 62	40 <sup>1</sup>	33.7611	47.576.11	S 31 52	41 <sup>1</sup>	33.8501	47.585.01	S 38 02	48	33.8557	47.585.57	S 38 60	49
33.7551	47.575.51	S 30 63	40 <sup>1</sup>	33.7613	47.576.13	S 31 53	41 <sup>1</sup>	33.8502	47.585.02	S 38 03	48	33.8559	47.585.59	S 38 61	49
33.7554	47.575.54	S 30 64	40 <sup>1</sup>	33.7614	47.576.14	S 31 60	41 <sup>1</sup>	33.8503	47.585.03	S 38 04	48	33.8560	47.585.60	S 39 63	50
33.7555	47.575.55	S 30 65	40 <sup>1</sup>	33.7615	47.576.15	S 31 59	41 <sup>1</sup>	33.8504	47.585.04	S 38 05	48	33.8561	47.585.61	S 39 64	50
33.7557	47.575.57	S 30 66	40 <sup>1</sup>	33.7616	47.576.16	S 31 57	41 <sup>1</sup>	33.8505	47.585.05	S 39 02	48	33.8563	47.585.63	S 39 51	50
33.7560	47.575.60	S 30 67	40 <sup>1</sup>	33.7617	47.576.17	S 31 58	41 <sup>1</sup>	33.8506	47.585.06	S 38 07	48	33.8564	47.585.64	S 38 72	49
33.7561	47.575.61	S 30 68	40 <sup>1</sup>	33.7618	47.576.18	S 31 56	41 <sup>1</sup>	33.8508	47.585.08	S 38 10	48	33.8565	47.585.65	S 39 65	50
33.7566	47.575.66	S 30 59	40 <sup>1</sup>	33.7619	47.576.19	S 31 55	41 <sup>1</sup>	33.8509	47.585.09	S 39 01	48	33.8566	47.585.66	S 39 66	50
33.7567	47.575.67	S 30 60	40 <sup>1</sup>	33.7620	47.576.20	S 30 82	40 <sup>1</sup>	33.8510	47.585.10	S 39 08	48	33.8567	47.585.67	S 39 68	50
33.7569	47.575.69	S 30 71	40	33.7623	47.576.23	S 30 83	40 <sup>1</sup>	33.8511	47.585.11	S 39 13	48	33.8568	47.585.68	S 39 55	50
33.7570	47.575.70	S 30 85	40 <sup>1</sup>	33.7623	47.576.23	S 32 75	42 <sup>1</sup>	33.8520	47.585.20	S 40 14	51	33.8569	47.585.69	S 39 56	50
33.7572	47.575.72	S 30 79	40 <sup>1</sup>	33.7624	47.576.24	S 30 69	40 <sup>1</sup>	33.8522	47.585.22	S 40 65	52	33.8570	47.585.70	S 39 54	50
33.7572	47.575.72	S 32 72	42 <sup>1</sup>	33.7624	47.576.24	S 32 73	42 <sup>1</sup>	33.8530	47.585.30	S 38 51	49	33.8570	47.585.70	S 40 15	51
33.7573	47.575.73	S 30 80	40 <sup>1</sup>	33.7625	47.576.25	S 31 61	41 <sup>1</sup>	33.8530	47.585.30	S 40 11	51	33.8574	47.585.74	S 39 91	51
33.7573	47.575.73	S 32 76	42 <sup>1</sup>	33.7626	47.576.26	S 31 62	41 <sup>1</sup>	33.8531	47.585.31	S 38 52	49	33.8574	47.585.74	S 40 16	51
33.7574	47.575.74	S 30 81	40 <sup>1</sup>	33.7627	47.576.27	S 31 63	41 <sup>1</sup>	33.8532	47.585.32	S 38 53	49	33.8575	47.585.75	S 40 12	51
33.7574	47.575.74	S 32 74	42 <sup>1</sup>	33.7628	47.576.28	S 31 64	41 <sup>1</sup>	33.8532	47.585.32	S 40 13	51	33.8576	47.585.76	S 39 59	50
33.7577	47.575.77	S 32 56	42	33.7629	47.576.29	S 30 84	40 <sup>1</sup>	33.8533	47.585.33	S 38 54	49	33.5747	47.557.47	S 40 01	51
33.7578	47.575.78	S 32 16	42	33.7630	47.576.30	S 31 67	41 <sup>1</sup>	33.8536	47.585.36	S 38 55	49	33.8619	47.586.19	S 40 02	51
33.7579	47.575.79	S 30 70	40	33.7631	47.576.31	S 31 65	41 <sup>1</sup>	33.8537	47.585.37	S 38 56	49	33.8619	47.586.19	S 40 20	51
33.7580	47.575.80	S 30 73	40 <sup>1</sup>	33.7632	47.576.32	S 31 68	41 <sup>1</sup>	33.8539	47.585.39	S 38 57	49	33.8567	47.585.67	S 40 04	51
33.7581	47.575.81	S 30 74	40 <sup>1</sup>	33.7633	47.576.33	S 31 69	41 <sup>1</sup>	33.8540	47.585.40	S 38 59	49	33.8690	47.586.90	S 39 81	50
33.7582	47.575.82	S 30 75	40 <sup>1</sup>	33.7634	47.576.34	S 31 70	41 <sup>1</sup>	33.8541	47.585.41	S 38 67	49	33.8691	47.586.91	S 39 82	50
33.7583	47.575.83	S 30 76	40 <sup>1</sup>	33.7635	47.576.35	S 31 66	41 <sup>1</sup>	33.8542	47.585.42	S 38 62	49	33.8692	47.586.92	S 39 83	50
								33.8543	47.585.43	S 38 58	49	33.8695	47.586.95	S 42 31	56

1) Sign with the same message as IMPA and ISSA sign, but with a different format

## IMO regulations and applicable standards

IMO Resolution A.654(16) adopted on 19 October 1989	Graphical symbols for fire control plans
IMO Resolution A.752(18) adopted on 4 November 1993	Guidelines for the evaluation, testing and application of low-location lighting on passenger ships
IMO Resolution A.760(18) adopted on 4 November 1993	Symbols related to life-saving appliances and arrangements
IMO Resolution A.952(23) adopted on 5 December 2003	Graphical symbols for shipboard fire control plans
IMO Polar Code	Code for Ships Operating in Polar Waters
SOLAS Convention 2004 chapter II-2 Regulation 13.3.2.5	Construction – Fire protection, fire detection and fire extinction - Means of escape - Marking of escape routes
SOLAS Convention 2004 chapter II-2 Regulation 13.7.2.2	Construction – Fire protection, fire detection and fire extinction - Means of escape - Instruction for safe escape
SOLAS Convention 2004 chapter III-Regulation 9.2.3	Life-saving appliances and arrangements - Operating instructions
MARPOL Annex V, 2012 Revision	International Convention for the Prevention of Pollution from Ships
ISPS Code 2003 adopted on 12 December 2002	International Ship and Port Facility Code
ICAO and IMO document 9636	International signs to provide guidance to persons at airports and marine terminals
IMDG Code 2014 Edition	International Maritime Dangerous Goods (IMDG) Code
ISM Code 2014 Edition	International Safety Management (ISM) Code
European Directive 2014/90/EU	Directive marine equipment repealed Directive 96/98/EC
ISO 24409-1:2010	Ships and marine technology - Design, location and use of shipboard safety signs, safety related signs, safety notices and safety markings - Part 1: Design principles
ISO 24409 - 2: 2014	Ships and marine technology - Design, location and use of shipboard safety signs, safety-related signs, safety notices and safety markings - Part 2: Catalogue
ISO 24409 - 3: 2014	Ships and marine technology - Design, location, and use of shipboard safety signs, safety-related signs, safety notices and safety markings - Part 3: Code of practise
ISO 16069:2004	Graphical symbols - Safety signs - Safety way guidance systems (SWGS)
ISO 3864-1:2011	Graphical symbols -Safety colours and safety signs - Part 1: Design principles for safety signs and safety markings
ISO 3864-2:2016	Graphical symbols - Safety colours and safety signs -Part 2: Design principles for product safety labels
ISO 17631:2002	Ships and marine technology -Shipboard plans for fire protection, life-saving appliances and means of escape
ISO 15370:2010	Ships and marine technology -Low-location lighting (LLL) on passenger ships -Arrangement
ISO 14726:2008	Ships and marine technology - Identification colours for the content of piping systems
ISO 20712-1:2008	Water safety signs and beach safety flags - Part 1: Specifications for water safety signs used in workplaces and public areas
EN ISO 7010:2012	Graphical symbols - Safety colours and safety signs -Registered safety signs
DIN 67510-1:2009	Photoluminescent pigments and products - Part 1: Measurement and marking at the producer.
DIN 67510-4:2008	Phosphorescent pigments and products - Part 4: Products for phosphorescent escape route systems - Markings and applications
REG 13-36 (PYC) Passenger yacht code January 2016	The code of practice for yachts carrying 13 to 36 passengers pleasure and leisure sector
MCA LY3, 2014	The Large Commercial Yatch Code (LY3)
NORSOK STANDARD L-004, 2016	Piping fabrication, installation, flushing and testing
NORSOK STANDARD C-002, Edition 4, September 2015	Architectural components and equipment
NORSOK STANDARD S-001, Edition 4, February 2008	Technical safety
2009 MODU CODE	IMO Code for the Construction and Equipment of Mobile Offshore Drilling Units, 2009
GOST R 12.2.143-2009	Occupational safety standards system. Photoluminescent evacuation systems. Requirements and methods of test
GOST R 12.4.026-2001	Occupational safety standards system. Safety colours, safety signs and signal marking. Purpose and rules of application. General technical

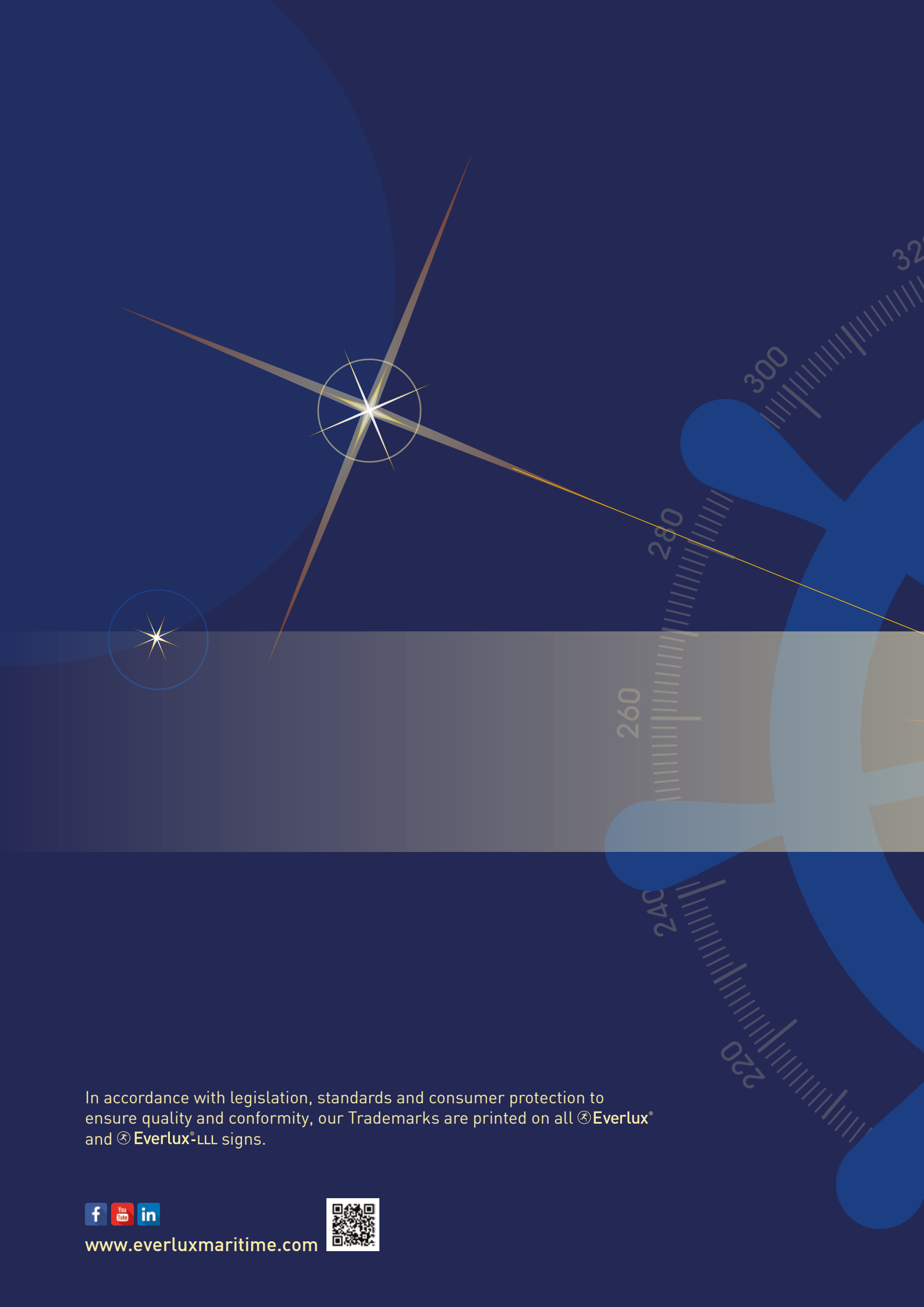

In accordance with legislation, standards and consumer protection to ensure quality and conformity, our Trademarks are printed on all  Everlux® and  Everlux®-LLL signs.



[www.everluxmaritime.com](http://www.everluxmaritime.com)

